



---

# HD Radio™ Air Interface Design Description Layer 1 AM

**Rev. F**  
**August 23, 2011**

## **TRADEMARKS**

HD Radio™ and the HD, HD Radio, and “Arc” logos are proprietary trademarks of iBiquity Digital Corporation.

“iBiquity”, “iBiquity Digital”, and the iBiquity Digital logo are also proprietary trademarks of iBiquity.

All other trademarks, whether claimed or registered, are the exclusive property of their respective owners.

### **iBiquity Digital Corporation**

6711 Columbia Gateway Drive, Suite 500

Columbia, MD 21046

Voice: 443-539-4290

Fax: 443-539-4291

**E-mail address:**

[info@ibiquity.com](mailto:info@ibiquity.com)

# Table of Contents

---

## Contents

<b>1</b>	<b>SCOPE .....</b>	<b>1</b>
1.1	System Overview .....	1
1.2	Document Overview .....	1
<b>2</b>	<b>REFERENCED DOCUMENTS .....</b>	<b>2</b>
<b>3</b>	<b>ABBREVIATIONS, SYMBOLS, AND CONVENTIONS .....</b>	<b>3</b>
3.1	Introduction .....	3
3.2	Abbreviations and Acronyms .....	3
3.3	Presentation Conventions .....	4
3.4	Mathematical Symbols .....	4
3.4.1	Variable Naming Conventions .....	4
3.4.2	Arithmetic Operators .....	5
3.5	AM System Parameters .....	5
<b>4</b>	<b>OVERVIEW .....</b>	<b>7</b>
4.1	Introduction .....	7
4.2	Waveforms and Spectra .....	7
4.2.1	Hybrid Waveform .....	7
4.2.2	All Digital Waveform .....	8
4.3	System Control Channel .....	8
4.4	Logical Channels .....	8
4.5	Functional Components .....	10
4.5.1	Scrambling .....	11
4.5.2	Channel Encoding .....	11
4.5.3	Interleaving .....	11
4.5.4	System Control Processing .....	11
4.5.5	OFDM Subcarrier Mapping .....	11
4.5.6	OFDM Signal Generation .....	11
4.5.7	Transmission Subsystem .....	11
<b>5</b>	<b>WAVEFORMS AND SPECTRA .....</b>	<b>12</b>
5.1	Introduction .....	12
5.2	Spectral Conventions .....	12
5.3	Hybrid Spectrum .....	12
5.4	All Digital Spectrum .....	15
<b>6</b>	<b>SYSTEM CONTROL CHANNEL .....</b>	<b>18</b>
6.1	Introduction .....	18
6.2	Service Mode Control .....	19
6.2.1	Service Mode Backward Compatibility .....	19
6.2.2	Service Mode Switching .....	20
6.3	Subcarrier Scaling Control Signals .....	21
6.3.1	Power Level Control .....	22

6.3.2	Reduced Digital Bandwidth Control .....	22
6.3.3	High-Power PIDS Control.....	22
6.4	Analog Audio Bandwidth Control.....	23
6.5	Absolute L1 Frame Number .....	23
6.6	L1 Block Count .....	24
<b>7</b>	<b>LOGICAL CHANNELS.....</b>	<b>25</b>
7.1	Introduction .....	25
7.2	Characterization Parameters .....	25
7.2.1	Transfer .....	25
7.2.2	Latency.....	26
7.2.3	Robustness.....	26
7.2.4	Assignment of Characterization Parameters.....	27
7.3	Spectral Mapping.....	28
7.4	Framing and Synchronization.....	30
<b>8</b>	<b>SCRAMBLING .....</b>	<b>31</b>
8.1	Scrambler Operation.....	31
<b>9</b>	<b>CHANNEL ENCODING .....</b>	<b>33</b>
9.1	Convolutional Encoding .....	34
9.1.1	Mother Code Generation.....	34
9.1.2	Puncturing .....	34
9.1.3	Parallel-to-Serial Conversion .....	34
9.1.4	Convolutional Encoders .....	34
9.1.4.1	E1 Convolutional Encoder .....	35
9.1.4.2	E2 Convolutional Encoder .....	35
9.1.4.3	E3 Convolutional Encoder .....	36
9.2	Channel Encoding Data Flow .....	37
9.2.1	Service Mode MA1 .....	37
9.2.2	Service Mode MA3 .....	38
<b>10</b>	<b>INTERLEAVING.....</b>	<b>39</b>
10.1	Introduction .....	39
10.2	Subframe Generation.....	42
10.3	Interleaver Matrices.....	43
10.3.1	PU, PL, S, and T Interleaver Matrices.....	43
10.3.2	Interleaver Matrix PIDS .....	45
10.4	Bit Mapping.....	46
10.5	Transfer Frame Time Alignment .....	46
10.6	Service Mode MA1 .....	46
10.7	Service Mode MA3 .....	47
<b>11</b>	<b>SYSTEM CONTROL PROCESSING .....</b>	<b>49</b>
11.1	Introduction .....	49
11.2	System Control Data Sequence Assembler.....	49
11.2.1	Block Synchronization (Sync).....	51
11.2.2	Power Level Indicator (PLI).....	51
11.2.3	High-Power PIDS Indicator (HPPI).....	51

11.2.4	Analog Audio Bandwidth Indicator (AABI).....	51
11.2.5	Reduced Digital Bandwidth Indicator (RDBI).....	51
11.2.6	L1 Block Count (BC).....	52
11.2.7	Service Mode Indicator (SMI).....	52
<b>12</b>	<b>OFDM SUBCARRIER MAPPING .....</b>	<b>53</b>
12.1	Introduction .....	53
12.2	OFDM Subcarrier Mapping Procedures.....	54
12.2.1	Primary Subcarriers.....	54
12.2.2	Secondary and Tertiary Subcarriers .....	56
12.2.2.1	Hybrid Waveform .....	56
12.2.2.2	All Digital Waveform .....	58
12.2.3	Reference Subcarriers.....	59
<b>13</b>	<b>OFDM SIGNAL GENERATION .....</b>	<b>61</b>
13.1	Introduction .....	61
13.2	Functionality.....	61
<b>14</b>	<b>TRANSMISSION SUBSYSTEM .....</b>	<b>63</b>
14.1	Introduction .....	63
14.2	Functional Components.....	65
14.2.1	Symbol Concatenation .....	65
14.2.2	Low-Pass Filtering .....	65
14.2.3	Analog Diversity Delay.....	65
14.2.4	Analog AM Modulator.....	65
14.2.5	Analog/Digital Combiner .....	66
14.2.6	Up-Conversion .....	66
<b>15</b>	<b>GLOSSARY .....</b>	<b>67</b>

# List of Figures

Figure 4-1: AM Air Interface L1 Functional Block Diagram..... 10

Figure 5-1: AM HD Radio Hybrid Waveform Spectrum (5 kHz Audio Configuration)..... 13

Figure 5-2: AM HD Radio Hybrid Waveform Spectrum (8 kHz Audio Configuration)..... 13

Figure 5-3: AM HD Radio Hybrid Waveform Spectrum (Reduced Digital Bandwidth Configuration) ..... 14

Figure 5-4: AM All Digital Waveform Spectrum..... 16

Figure 5-5: AM HD Radio All Digital Waveform Spectrum (Reduced Digital Bandwidth Configuration) ..... 16

Figure 6-1: System Control Channel ..... 18

Figure 6-2: L1 Frames and Blocks ..... 24

Figure 7-1: Transfer Frame Timing Relationships ..... 26

Figure 7-2: Logical Channel Spectral Mapping – Service Mode MA1 (5 kHz Audio Configuration)..... 28

Figure 7-3: Logical Channel Spectral Mapping – Service Mode MA1 (Reduced Digital Bandwidth Configuration) 28

Figure 7-4: Logical Channel Spectral Mapping – Service Mode MA3 ..... 29

Figure 7-5: Logical Channel Spectral Mapping – Service Mode MA3 (Reduced Digital Bandwidth Configuration) 29

Figure 8-1: Scrambling Functional Block Diagram..... 31

Figure 8-2: Scrambler Block Diagram..... 32

Figure 9-1: Channel Encoding Functional Block Diagram ..... 33

Figure 9-2: E1 Convolutional Encoder ..... 35

Figure 9-3: E2 Convolutional Encoder ..... 36

Figure 9-4: E3 Convolutional Encoder ..... 36

Figure 9-5: Channel Encoding – Service Mode MA1 ..... 37

Figure 9-6: Channel Encoding – Service Mode MA3 ..... 38

Figure 10-1: Interleaving Conceptual Block Diagram..... 39

Figure 10-2: Interleaver Row and Column Indices vs k ..... 44

Figure 10-3: PIDS Interleaver Row Indices vs. k ..... 45

Figure 10-4: Interleaving – Service Mode MA1..... 47

Figure 10-5: PIDS Interleaving Process – All Service Modes..... 47

Figure 10-6: Interleaving – Service Mode MA3..... 48

Figure 11-1: System Control Processing Conceptual Diagram ..... 49

Figure 11-2: System Control Data Sequence..... 50

Figure 12-1: OFDM Subcarrier Mapping Functional Block Diagram..... 53

Figure 12-2: Assignment of Output Vector X Elements to Subcarriers ..... 53

Figure 13-1: OFDM Signal Generation Conceptual Block Diagram..... 61

Figure 13-2: Pulse Shaping Function..... 62

Figure 14-1: Hybrid Transmission Subsystem Functional Block Diagram ..... 63

Figure 14-2: All Digital Transmission Subsystem Functional Block Diagram ..... 64

## List of Tables

Table 4-1: Approximate Information Rate of AM Logical Channels.....	8
Table 5-1: AM Hybrid Waveform Spectral Summary.....	14
Table 5-2: AM All Digital Waveform Spectral Summary.....	17
Table 6-1: Transfer through the SCCH.....	18
Table 6-2: PSM Bit Assignments .....	19
Table 6-3: Reserved Service Modes – Defaults.....	19
Table 6-4: Subcarrier Scaling Control Signal States for Service Mode MA1 .....	21
Table 6-5: Subcarrier Scaling Control Signal States for Service Mode MA3 .....	21
Table 6-6: BC Bit Assignments.....	24
Table 7-1: Transfer Frame Rate Relationships .....	25
Table 7-2: Latency Summary .....	26
Table 7-3: Logical Channel Characterization – Service Mode MA1 .....	27
Table 7-4: Logical Channel Characterization – Service Mode MA3 .....	27
Table 9-1: AM Convolutional Codes.....	34
Table 9-2: E1 Convolutional Encoder Generator Polynomials – Rate 1/3 Mother Code .....	35
Table 9-3: E2 Convolutional Encoder Generator Polynomials.....	35
Table 9-4: E3 Convolutional Encoder Generator Polynomials.....	36
Table 10-1: Transfer Frame Characteristics – Service Mode MA1 .....	40
Table 10-2: Transfer Frame Characteristics – Service Mode MA3 .....	40
Table 10-3: Summary of Logical Channel Processing in the Interleaver .....	41
Table 10-4: Number of Bits per Interleaver Matrix Element.....	43
Table 10-5: Training Bit Patterns .....	44
Table 11-1: System Control Data Sequence Bit Allocations.....	50
Table 11-2: L1 Block Count Bit Assignments.....	52
Table 11-3: AM HD Radio Service Mode Bit Assignments .....	52
Table 12-1: 64-QAM Constellation Mapping.....	54
Table 12-2: Primary Interleaver Subcarrier Mapping – Hybrid Waveform.....	56
Table 12-3: Primary Interleaver Subcarrier Mapping – All Digital Waveform.....	56
Table 12-4: QPSK Constellation Mapping.....	57
Table 12-5: 16-QAM Constellation Mapping.....	57
Table 12-6: Secondary and Tertiary Interleaver Subcarrier Mapping – Hybrid Waveform .....	58
Table 12-7: PIDS Interleaver Subcarrier Mapping – Hybrid Waveform.....	58
Table 12-8: Secondary and Tertiary Interleaver Subcarrier Mapping – All Digital Waveform .....	59
Table 12-9: PIDS Interleaver Subcarrier Mapping – All Digital Waveform.....	59
Table 12-10: BPSK Signal Constellation Mapping.....	59
Table 12-11: Signal Constellation Scale Factors.....	59
Table 12-12: R Subcarrier Mapping – Hybrid and All Digital Waveforms.....	60

# 1 Scope

## 1.1 System Overview

The iBiquity Digital Corporation HD Radio™ system is designed to permit a smooth evolution from current analog amplitude modulation (AM) and frequency modulation (FM) radio to a fully digital in-band on-channel (IBOC) system. This system delivers digital audio and data services to mobile, portable, and fixed receivers from terrestrial transmitters in the existing medium frequency (MF) and very high frequency (VHF) radio bands. Broadcasters may continue to transmit analog AM and FM simultaneously with the new, higher-quality, and more robust digital signals, allowing themselves and their listeners to convert from analog to digital radio while maintaining their current frequency allocations.

## 1.2 Document Overview

This document defines the generation of Layer 1 AM HD Radio signals for transmission over the air to receiving equipment. It describes how control and information are passed through the Layer 1 AM air interface to generate an HD Radio signal. It focuses on the creation of the transmitted AM HD Radio signal; specific hardware and software implementation is not described.



## 2 Referenced Documents

### STATEMENT

Each referenced document that is mentioned in this document shall be listed in the following iBiquity document:

- Reference Documents for the NRSC In-Band/On-Channel Digital Radio Broadcasting Standard  
Document Number: SY\_REF\_2690s

## 3 Abbreviations, Symbols, and Conventions

### 3.1 Introduction

Section 3 presents the following items pertinent to a better understanding of this document:

- Abbreviations and Acronyms
- Presentation Conventions
- Mathematical Symbols
- AM System Parameters

Note: A glossary defining the technical terms used herein is provided at the end of this document.

### 3.2 Abbreviations and Acronyms

AAB	Analog Audio Bandwidth Control
AABI	Analog Audio Bandwidth Indicator
ALFN	Absolute L1 Frame Number
AM	Amplitude Modulation
BC	L1 Block Count
BPSK	Binary Phase Shift Keying
FM	Frequency Modulation
GCS	Grounded Conductive Structures
GPS	Global Positioning System
HPP	High-Power PIDS Control
HPPI	High-Power PIDS Indicator
IBOC	In-band On-channel
IDS	IBOC Data Service
kbit/s	kilobits per second
L1	Layer 1
L2	Layer 2
LC	Logical Channel
MA1	AM Hybrid Service Mode 1
MA3	AM All Digital Service Mode 3
MF	Medium Frequency
N/A	Not Applicable
OFDM	Orthogonal Frequency Division Multiplexing
P1–P3	Primary Logical Channels 1 through 3
PDU	Protocol Data Unit
PIDS	Primary IBOC Data Service Logical Channel
PL	Power Level Control
PLI	Power Level Indicator
PSM	Service Mode Control
QAM	Quadrature Amplitude Modulation
QPSK	Quadrature Phase Shift Keying
RDB	Reduced Digital Bandwidth Control
RDBI	Reduced Digital Bandwidth Indicator
RF	Radio Frequency
SCCH	System Control Channel

SIS	Station Information Service
SMI	Service Mode Indicator
UTC	Coordinated Universal Time
VHF	Very High Frequency

### 3.3 Presentation Conventions

Unless otherwise noted, the following conventions apply to this document:

- Glossary terms are presented in italics upon their first usage in the text.
- All vectors are indexed starting with 0.
- The element of a vector with the lowest index is considered to be first.
- In drawings and tables, the leftmost bit is considered to occur first in time.
- Bit 0 of a byte or word is considered the least significant bit.
- When presenting the dimensions of a matrix, the number of rows is given first (e.g., an  $n \times m$  matrix has  $n$  rows and  $m$  columns).
- In timing diagrams, earliest time is on the left.
- Binary numbers are presented with the most significant bit having the highest index.
- In representations of binary numbers, the least significant bit is on the right.

### 3.4 Mathematical Symbols

#### 3.4.1 Variable Naming Conventions

The variable naming conventions defined below are used throughout this document.

Category	Definition	Examples
Lower and upper case letters	Indicates scalar quantities	$i, j, J, g_{11}$
Underlined lower and upper case letters	Indicates vectors	$\underline{u}, \underline{V}$
Double underlined lower and upper case letters	Indicates two-dimensional matrices	$\underline{\underline{u}}, \underline{\underline{V}}$
[i]	Indicates the $i^{\text{th}}$ element of a vector, where $i$ is a non-negative integer	$\underline{u}[0], \underline{V}[1]$
[ ]	Indicates the component of a vector	$\underline{v} = [0, 10, 6, 4]$
[i] [j]	Indicates the element of a two-dimensional matrix in the $i^{\text{th}}$ row and $j^{\text{th}}$ column, where $i$ and $j$ are non-negative integers	$\underline{\underline{u}}[i][j], \underline{\underline{V}}[i][j]$
[ ]	Indicates the components of a matrix	$\underline{\underline{m}} = \begin{bmatrix} 0 & 3 & 1 \\ 2 & 7 & 5 \end{bmatrix}$
$n \dots m$	Indicates all the integers from $n$ to $m$ , inclusive	$3 \dots 6 = 3, 4, 5, 6$

Category	Definition	Examples
n:m	Indicates bit positions n through m of a binary sequence or vector	Given a binary vector $i = [0, 1, 1, 0, 1, 1, 0, 0]$ , $i_{2:5} = [1, 0, 1, 1]$

### 3.4.2 Arithmetic Operators

The arithmetic operators defined below are used throughout this document.

Category	Definition	Examples
.	Indicates a multiplication operation	$3 \cdot 4 = 12$
INT()	Indicates the integer portion of a real number	$\text{INT}(5/3) = 1$ $\text{INT}(-1.8) = -1$
a MOD b	Indicates a modulo operation	$33 \text{ MOD } 16 = 1$
$\oplus$	Indicates modulo-2 binary addition	$1 \oplus 1 = 0$
	Indicates the concatenation of two vectors	$\underline{A} = [\underline{B} \mid \underline{C}]$ The resulting vector $\underline{A}$ consists of the elements of $\underline{B}$ followed by the elements of $\underline{C}$ .
j	Indicates the square-root of -1	$j = \sqrt{-1}$
Re()	Indicates the real component of a complex quantity	If $x = (3 + j4)$ , $\text{Re}(x) = 3$
Im()	Indicates the imaginary component of a complex quantity	If $x = (3 + j4)$ , $\text{Im}(x) = 4$
$\log_{10}$	Indicates the base-10 logarithm	$\log_{10}(100) = 2$
*	Indicates complex conjugate	If $x = (3 + j4)$ , $x^* = (3 - j4)$
x	Indicates the absolute value of x	$ -5  = 5$ $ 3 - 4j  = 5$

### 3.5 AM System Parameters

The AM system parameters defined below are used throughout this document.

Parameter Name	Symbol	Units	Exact Value	Computed Value (To 4 significant figures)
OFDM Subcarrier Spacing	$\Delta f$	Hz	1488375/8192	181.7
Cyclic Prefix Width	$\alpha$	none	7/128	$5.469 \times 10^{-2}$
OFDM Symbol Duration	$T_s$	s	$(1+\alpha) / \Delta f = (135/128) \cdot (8192/1488375)$	$5.805 \times 10^{-3}$
OFDM Symbol Rate	$R_s$	Hz	$= 1/T_s$	172.3
L1 Frame Duration	$T_f$	s	$65536/44100 = 256 \cdot T_s$	1.486
L1 Frame Rate	$R_f$	Hz	$= 1/T_f$	$6.729 \times 10^{-1}$
L1 Block Duration	$T_b$	s	$= 32 \cdot T_s$	$1.858 \times 10^{-1}$
L1 Block Rate	$R_b$	Hz	$= 1/T_b$	5.383

Parameter Name	Symbol	Units	Exact Value	Computed Value (To 4 significant figures)
Digital Diversity Delay Frames	$N_{dd}$	none	3	3
Digital Diversity Delay Time	$T_{dd}$	s	$= N_{dd} \cdot T_f$	4.458
Analog Diversity Delay Time	$T_{ad}$	s	$4.5 \cdot T_f$	6.687

## 4 Overview

### 4.1 Introduction

Layer 1 of the AM system converts information from *Layer 2* (L2) and system control from the *Configuration Administrator* into an AM HD Radio waveform for transmission in the existing allocation in the MF band. Information and control are transported in discrete *transfer frames* via multiple *logical channels*. These transfer frames are referred to as *Layer 2 Protocol Data Units* (PDUs).

The L2 PDUs vary in size and format depending on the *service mode*. The service mode, a major component of system control, determines the transmission characteristics of each logical channel. After assessing the requirements of their candidate applications, higher protocol layers select service modes that most suitably configure the logical channels. The plurality of logical channels reflects the inherent flexibility of the system, which supports simultaneous delivery of various classes of digital audio and data.

Layer 1 also receives system control from the Configuration Administrator for use by the Layer 1 System Control Processor.

This section presents the following:

- An overview of the waveforms and spectra
- An overview of the system control, including the available service modes
- An overview of the logical channels
- A high-level discussion of each of the functional components included in the Layer 1 AM air interface

Note: Throughout this document, various system parameters are globally represented as mathematical symbols. Refer to Subsection 3.5 for their values.

### 4.2 Waveforms and Spectra

The design provides a flexible means of transitioning to a digital broadcast system by providing two new waveform types: *Hybrid* and *All Digital*. The Hybrid waveform retains the analog AM signal, while the All Digital waveform does not. Both new waveform types conform to the current *spectral emissions mask*.

The digital signal is modulated using *Orthogonal Frequency Division Multiplexing* (OFDM). OFDM is a parallel modulation scheme in which the data stream modulates a large number of orthogonal subcarriers that are transmitted simultaneously. OFDM is inherently flexible, readily allowing the mapping of logical channels to different groups of subcarriers.

Refer to Section 5 for a detailed description of the spectra of the two waveform types.

#### 4.2.1 Hybrid Waveform

In the Hybrid waveform, the digital signal is transmitted in *primary* and *secondary* sidebands on both sides of the host *analog signal*, as well as underneath the host analog signal in *tertiary sidebands*. The bandwidth of the analog audio can be either 5 kHz or 8 kHz, as shown in Figure 5-1 and Figure 5-2 respectively (see Subsection 5.3). If the 8 kHz bandwidth is selected, then the secondary sidebands are also underneath the host analog signal. A reduced digital bandwidth configuration is also provided where an analog audio bandwidth of up to 9.4 kHz can be accommodated, as shown in Figure 5-3.

The levels of the *OFDM subcarriers* within each *primary sideband* are all the same. However, the levels of the two primary sidebands are adjustable independently.

The secondary and tertiary sideband levels may be set to one of two selectable values. In addition, there are two reference subcarriers for system control whose levels are fixed at a value that is different from the sidebands.

The analog host is a monophonic signal. The Hybrid system does not support analog AM stereo transmissions.

#### 4.2.2 All Digital Waveform

The greatest system enhancements are realized with the All Digital waveform. In this waveform, the analog signal is replaced with the primary sidebands whose power is increased relative to the Hybrid waveform levels. In addition, the secondary and tertiary sidebands are moved to both sides of the primary sidebands, and their power is also increased relative to the Hybrid levels. The end result is a higher power digital signal with an overall bandwidth reduction. These changes provide a more robust digital signal that is less susceptible to adjacent channel interference. Reference subcarriers are also provided to convey system control information. Their levels are fixed at a value that is different than that of the sidebands.

### 4.3 System Control Channel

The *system control channel* (SCCH) transports control and status information. The *service mode control* (PSM), *analog audio bandwidth control* (AAB), and *power level control* (PL) are input to Layer 1 from the Configuration Administrator, while status information is sent from Layer 1 to Layer 2.

Two service modes dictate all permissible configurations of the logical channels. They are:

- Hybrid service mode MA1
- All Digital service mode MA3

Refer to Section 6 for a detailed description of the SCCH and Section 11 for a detailed description of *system control processing*.

### 4.4 Logical Channels

A logical channel is a signal path that conducts L2 PDUs in transfer frames into and out of Layer 1 with a specific grade of service, determined by service mode. Layer 1 of the AM air interface provides three logical channels to higher layer protocols: P1, P3, and PIDS. P1 and P3 are intended for general purpose audio and data transfer, while PIDS is designed to carry the Station Information Service (SIS) data. The P1 logical channel is designed to be more robust than the P3 logical channel. This allows a transfer of information that can be tailored to conform to a number of diverse applications.

The approximate information rates of the three logical channels for each of the service modes are shown in Table 4-1. Calculation of the exact rates is explained in Section 7.

Table 4-1: Approximate Information Rate of AM Logical Channels

Service Mode	Approximate Channel Information Rate (kbit/s)			Waveform
	P1	P3	PIDS	
MA1	20	16	0.4	Hybrid
MA3	20	20	0.4	All Digital

The performance of each logical channel is completely described through three *characterization parameters*: *transfer*, *latency*, and *robustness*. *Channel encoding*, *spectral mapping*, *interleaver depth*, and digital *diversity delay* are the components of these characterization parameters. The service mode uniquely configures these components for each active logical channel, thereby allowing the assignment of appropriate characterization parameters.

In addition, the service mode specifies the framing and synchronization of the transfer frames through each active logical channel. Refer to Section 7 for a detailed description of the logical channels and their configuration.



### 4.5 Functional Components

This subsection includes a high-level description of each Layer 1 functional block and the associated signal flow. Figure 4-1 is a functional block diagram of the Layer 1 processing. Some processing stages shown in Figure 4-1 are denoted by a logical channel subscript. For example, logical channel designations are subscripted with an “S” after *scrambling* and with a “G” after channel encoding. The single underline notation for a logical channel name refers to the fact that data is passed between the various functions as *vectors*. Each logical channel has a dedicated scrambler and channel encoder. The configuration administrator is a system function that configures each of the layers using SCCH information or parameters which do not change often. However, dynamic SCCH parameters such as the L1 Block Count and ALFN are sent from Layer 1 to Layer 2.

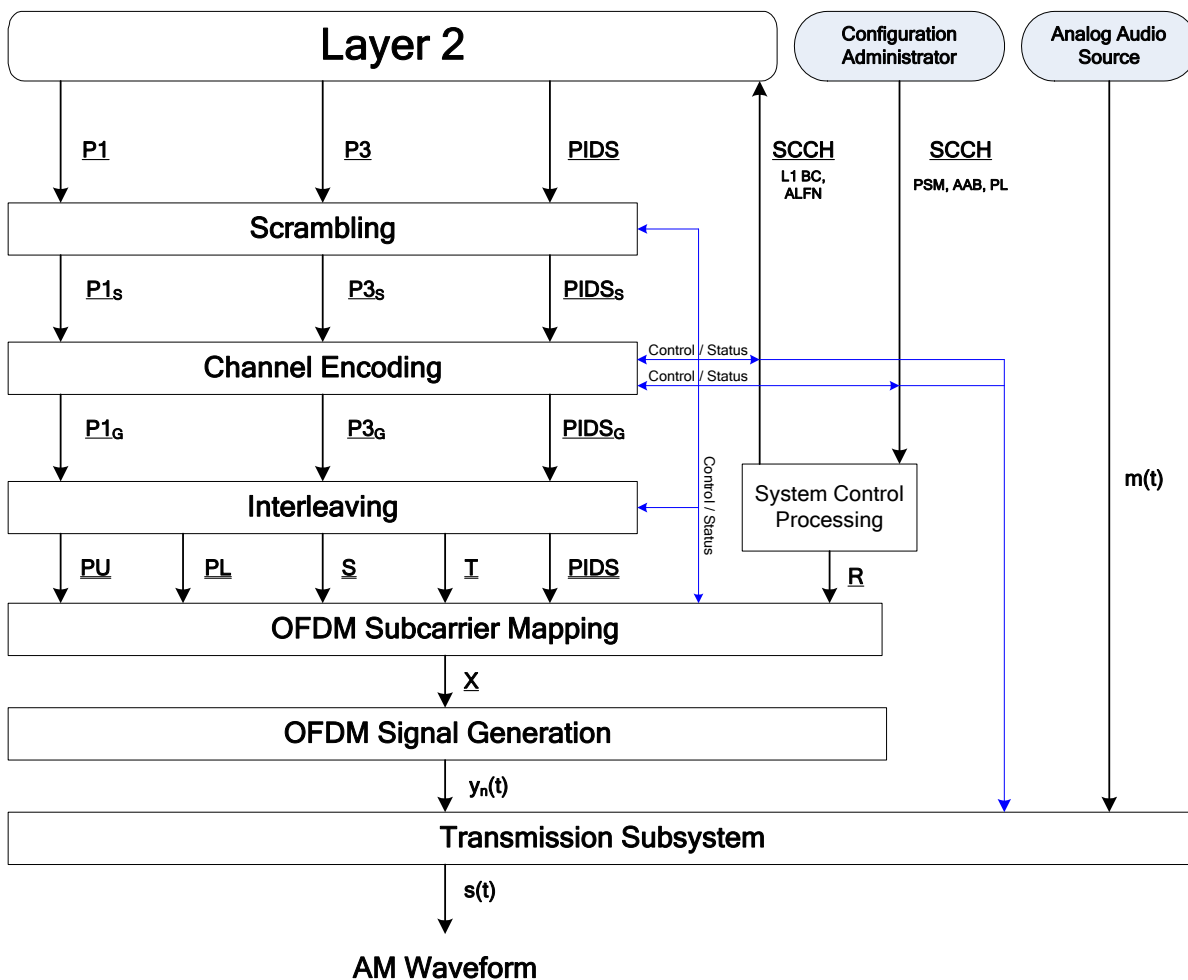

Figure 4-1: AM Air Interface L1 Functional Block Diagram

#### 4.5.1 Scrambling

This function randomizes the digital data carried in each logical channel to mitigate signal periodicities. At the output of scrambling, the logical channel vectors retain their identity but are distinguished by the “S” subscript (for example, “ $P_{1S}$ ”). Refer to Section 8 for a detailed description of the scrambling functional component.

#### 4.5.2 Channel Encoding

This function uses *convolutional encoding* to add redundancy to the digital data in each logical channel to improve its reliability in the presence of channel impairments. The size of the logical channel vectors is increased in inverse proportion to the *code rate*. The encoding techniques are configurable by service mode. At the output of the channel encoder, the logical channel vectors retain their identity, but are distinguished by the “G” subscript (for example, “ $P_{1G}$ ”). Refer to Section 9 for a detailed description of the channel encoding functional component.

#### 4.5.3 Interleaving

*Interleaving* in time and frequency is employed to mitigate the effects of burst errors. The interleaving techniques are tailored to the MF non-uniform interference environment and are configurable by service mode. In this process, the logical channels lose their identity. The interleaver output is structured in a matrix format. Each matrix consists of information from whole or partial logical channels and is associated with a specific portion of the transmitted spectrum. The *interleaver matrix* designations reflect the spectral mapping; “ $P_U$ ” and “ $P_L$ ”, for example, map to the primary sidebands while S and T map to the secondary and tertiary sidebands respectively. Digital diversity delay is also imposed on selected logical channels. Refer to Section 10 for a detailed description of the interleaving functional component.

#### 4.5.4 System Control Processing

This function generates a vector of *system control data sequences* that includes system control information received from the Configuration Administrator (such as service mode), and status for broadcast on the reference subcarriers. This data vector is designated “ $R$ ” for “reference.” Refer to Section 11 for a detailed description of the system control processing functional component.

#### 4.5.5 OFDM Subcarrier Mapping

This function assigns the interleaver matrices and system control vector to OFDM subcarriers. One row of each active interleaver matrix and one bit of the system control vector is processed each *OFDM symbol* (every  $T_S$  seconds) to produce one output vector  $\underline{X}$ , which is a frequency-domain representation of the signal. The mapping is specifically tailored to the non-uniform interference environment encountered in the AM band and is a function of the service mode. Refer to Section 12 for a detailed description of the *OFDM subcarrier mapping* functional component.

#### 4.5.6 OFDM Signal Generation

This function generates the digital portion of the time-domain AM HD Radio waveform. The input vectors  $\underline{X}$  are transformed into a shaped time-domain baseband pulse,  $y_n(t)$ , defining one OFDM symbol. Refer to Section 13 for a detailed description of the *OFDM Signal Generation* functional component.

#### 4.5.7 Transmission Subsystem

This function formats the baseband waveform for transmission through the MF channel. Major sub-functions include *symbol concatenation* and frequency up-conversion. When transmitting the Hybrid waveform, this function modulates the AM analog audio source and combines it with the digital signal to form a composite Hybrid signal,  $s(t)$ , ready for transmission. Refer to Section 14 for a detailed description of the *transmission subsystem* functional components.

## 5 Waveforms and Spectra

### 5.1 Introduction

This section describes the output spectrum for Hybrid and All Digital waveforms. Each spectrum is divided into several sidebands, which represent various subcarrier groupings. All spectra are represented at baseband.

### 5.2 Spectral Conventions

Each spectrum described in the following subsections shows the subcarrier number and center frequency of certain key OFDM subcarriers. The center frequency of a subcarrier is calculated by multiplying the subcarrier number by the OFDM subcarrier spacing  $\Delta f$ . The center of subcarrier 0 is located at 0 Hz. In this context, the center frequency is relative to the radio frequency (RF) *allocated channel*.

### 5.3 Hybrid Spectrum

The digital signal is transmitted in primary and secondary sidebands on both sides of the analog host signal, as well as in tertiary sidebands beneath the analog host signal as shown in Figure 5-1. In this configuration, the analog audio bandwidth is limited to 5 kHz. If the bandwidth of the analog audio exceeds 5 kHz, the secondary sidebands are also beneath the analog host signal as shown in Figure 5-2 (See Subsection 6.4). In this configuration, the analog audio bandwidth is limited to 8 kHz.

Optionally, the secondary, tertiary, and inner PIDS subcarriers may be disabled so that only the primary and outer PIDS sidebands are transmitted; this allows for an analog audio bandwidth of up to 9.4 kHz. Refer to Figure 5-3 for an illustration.

Status and control information is transmitted on reference subcarriers located on both sides of the main carrier. Each sideband has both an upper and a lower component. The PIDS logical channel is transmitted in individual subcarriers just above and below the frequency edges of the upper and lower secondary sidebands. The power level of each OFDM subcarrier is fixed relative to the other subcarriers within the same sideband. However, the absolute power levels of entire sidebands are adjustable.

Table 5-1 summarizes the spectral characteristics of the Hybrid waveform. Individual subcarriers are numbered from -81 to 81 with the center subcarrier at subcarrier number 0. Table 5-1 lists the approximate frequency ranges and bandwidths for each sideband. In Table 5-1, the subcarriers 54 to 56 and -54 to -56 are not represented. This is because they are not transmitted to avoid interference with first adjacent signals.

The *amplitude scale factors* listed in Table 5-1 and Table 5-2 refer to the multiplication constants used to scale the individual subcarriers to the appropriate power levels as defined in [9]. Refer to Section 12 for details of the subcarrier scaling operation. Refer to Subsection 6.3 for a description of the control signals that are used to select the amplitude scale factors. The resolution of the amplitude scale factors, and the actual point or points within the signal path where they are applied depends on the specific implementation and is outside the scope of this document.

For the Hybrid waveform illustrated in Figure 5-1 and Figure 5-2, all of the subcarriers within the Primary Lower sideband share a common scale factor,  $CH_{PL}$ , so that these subcarriers have the same amplitude relative to one another. Similarly, all of the subcarriers within the Primary Upper sideband share a common scale factor,  $CH_{PU}$ , so that these subcarriers have the same amplitude relative to one another. However,  $CH_{PL}$  and  $CH_{PU}$  may be different; the upper and lower sidebands may differ in average power level (asymmetric sidebands). Normally, the sideband power levels are equal, but under certain scenarios, asymmetric sidebands may be useful in order to compensate for antenna systems that do not have a symmetric frequency response or in order to reduce potential interference to another broadcast on an adjacent channel.

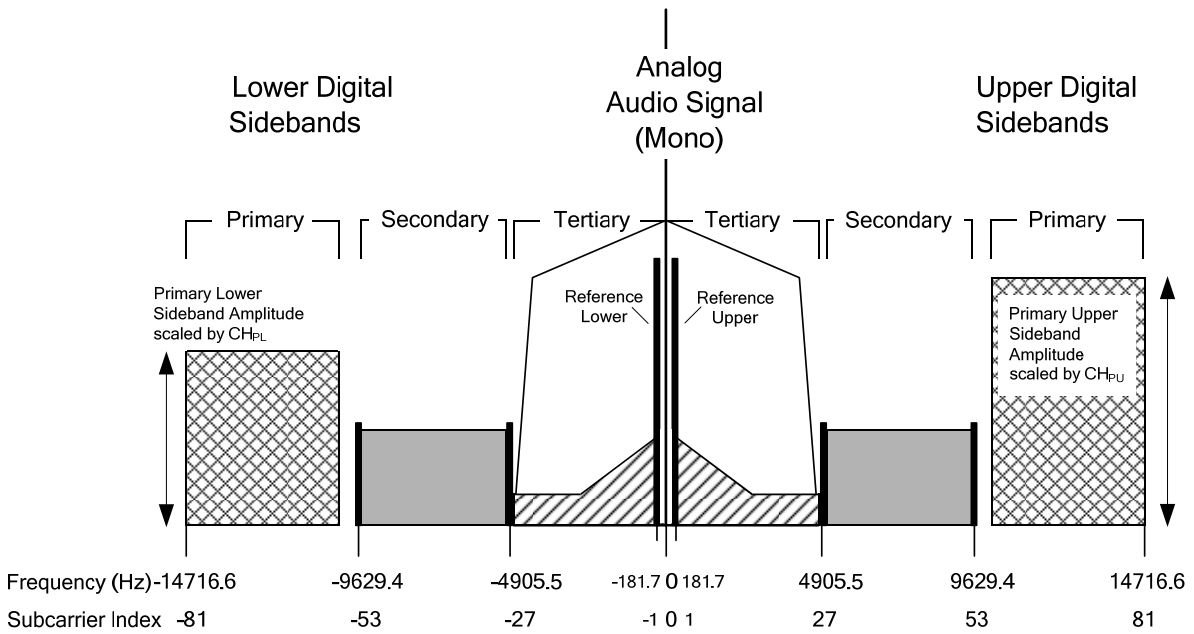

Figure 5-1: AM HD Radio Hybrid Waveform Spectrum (5 kHz Audio Configuration)

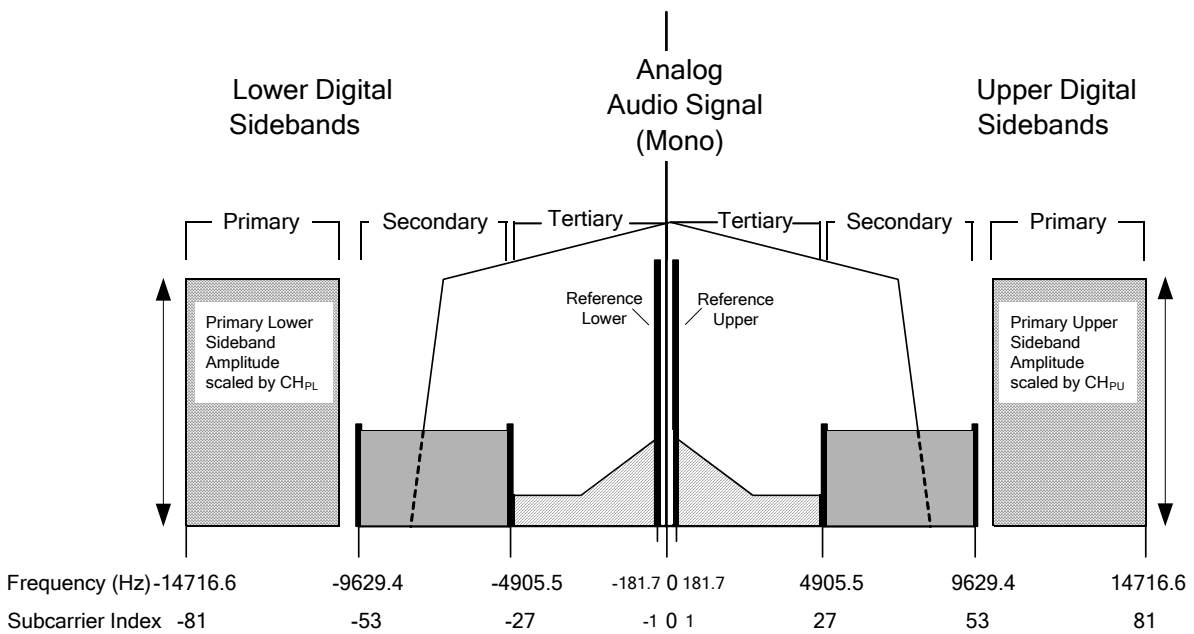

Figure 5-2: AM HD Radio Hybrid Waveform Spectrum (8 kHz Audio Configuration)

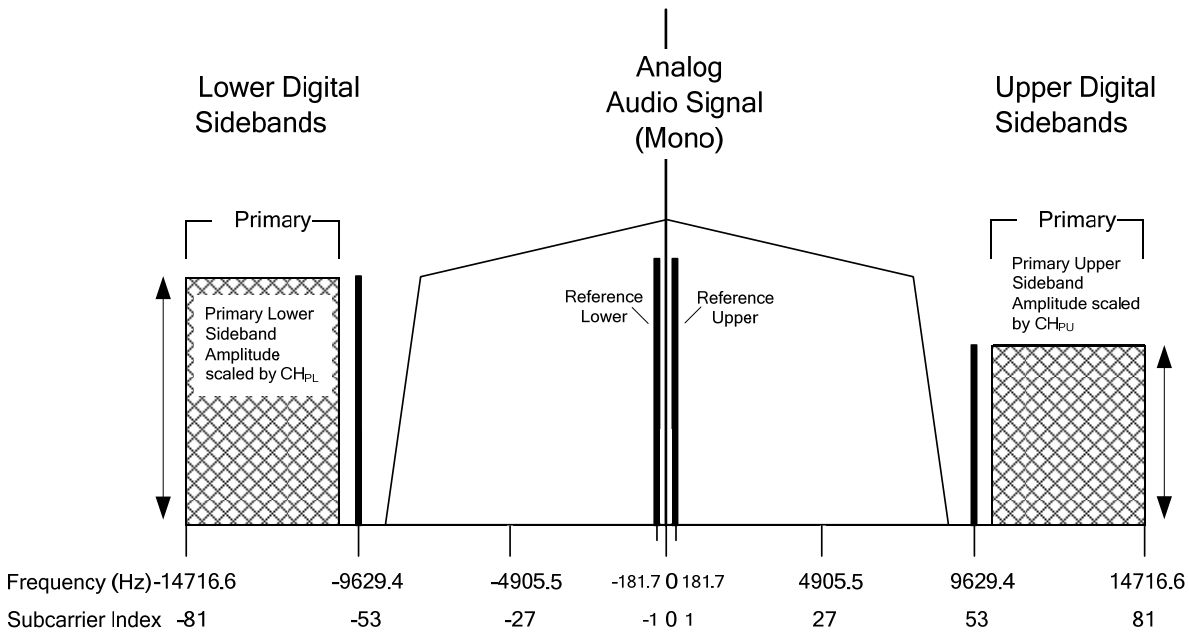

Figure 5-3: AM HD Radio Hybrid Waveform Spectrum (Reduced Digital Bandwidth Configuration)

Table 5-1: AM Hybrid Waveform Spectral Summary

Sideband	Subcarrier Range	Subcarrier Frequencies (Hz from channel center) <sup>†</sup>	Amplitude Scale Factor	Comments
Primary Upper	57 to 81	10356.1 to 14716.6	CH <sub>PU</sub>	Power adjustable as defined in [9]. Primary Upper and Lower Sidebands may be adjusted independently.
Primary Lower	-57 to -81	-10356.1 to -14716.6	CH <sub>PL</sub>	Power adjustable as defined in [9]. Primary Upper and Lower Sidebands may be adjusted independently.
Secondary Upper	28 to 52	5087.2 to 9447.7	CH <sub>S1</sub> or CH <sub>S2</sub> or 0.0	Power adjustable as defined by the Power level control setting defined in Subsection 6.3.1. Sideband may also be disabled by the control signal defined in Subsection 6.3.2.
Secondary Lower	-28 to -52	-5087.2 to -9447.7	CH <sub>S1</sub> or CH <sub>S2</sub> or 0.0	Power adjustable as defined by the Power level control setting defined in Subsection 6.3.1. Sideband may also be disabled by the control signal defined in Subsection 6.3.2.

<sup>†</sup> Subcarrier frequencies shown refer to the center frequency of the subcarrier.

Sideband	Subcarrier Range	Subcarrier Frequencies (Hz from channel center) <sup>†</sup>	Amplitude Scale Factor	Comments
Tertiary Upper	2 to 26	363.4 to 4723.8	$CH_{T1}[0:24]$ or $CH_{T2}[0:24]$ or 0.0	Each subcarrier in this sideband has a unique scale factor. Sideband may also be disabled by the control signal defined in Subsection 6.3.2.
Tertiary Lower	-2 to -26	-363.4 to -4723.8	$CH_{T1}[0:24]$ or $CH_{T2}[0:24]$ or 0.0	Each subcarrier in this sideband has a unique scale factor. Sideband may also be disabled by the control signal defined in Subsection 6.3.2.
Reference Upper	1	181.7	$CH_B$	
Reference Lower	-1	-181.7	$CH_B$	
PIDS1	27	4905.5	$CH_{I1}$ or $CH_{I2}$	Power adjustable as defined by the Power level control setting defined in Subsection 6.3.1. Sideband may be disabled by the control signal defined in Subsection 6.3.2.
PIDS2	53	9629.4	$CH_{PU} \cdot CH_{I3}$ or $CH_{PU} \cdot CH_{I4}$ or $CH_{PU} \cdot CH_{I5}$	Power adjustable, relative to the Primary Upper sideband power, as defined by the control signal settings defined in Subsection 6.3.
PIDS1*	-27	-4905.5	$CH_{I1}$ or $CH_{I2}$	* denotes complex conjugate Power adjustable as defined by the Power level control setting defined in Subsection 6.3.1. Sideband may be disabled by the control signal defined in Subsection 6.3.2.
PIDS2*	-53	-9629.4	$CH_{PL} \cdot CH_{I3}$ or $CH_{PL} \cdot CH_{I4}$ or $CH_{PL} \cdot CH_{I5}$	* denotes complex conjugate Power adjustable, relative to the Primary Lower sideband power, as defined by the control signal settings defined in Subsection 6.3.

#### 5.4 All Digital Spectrum

In the All Digital waveform, the analog signal is replaced with higher power primary sidebands. The unmodulated AM carrier is retained. In addition, the secondary *upper sideband* moves to the higher frequencies above the primary upper sideband and the tertiary *lower sideband* moves to the lower frequencies below the primary lower sideband. The secondary lower and tertiary upper sidebands are no longer used. Furthermore, the power of both the secondary and tertiary sidebands is increased. These changes result in the overall bandwidth being reduced, making the All Digital waveform less susceptible to adjacent channel interference. The reference subcarriers are located on both sides of the unmodulated AM carrier as in the Hybrid waveform, but at a higher level. The spectrum of the All Digital waveform is illustrated in Figure 5-4.

Optionally, the secondary and tertiary subcarriers may be disabled so that only the primary and PIDS sidebands are transmitted, reducing the total transmission bandwidth to less than 9.4 kHz. Refer to Figure 5-5 for an illustration.

The power level of each of the OFDM subcarriers within a sideband is fixed relative to the unmodulated main analog carrier. Table 5-2 summarizes the spectral characteristics of the All Digital waveform.

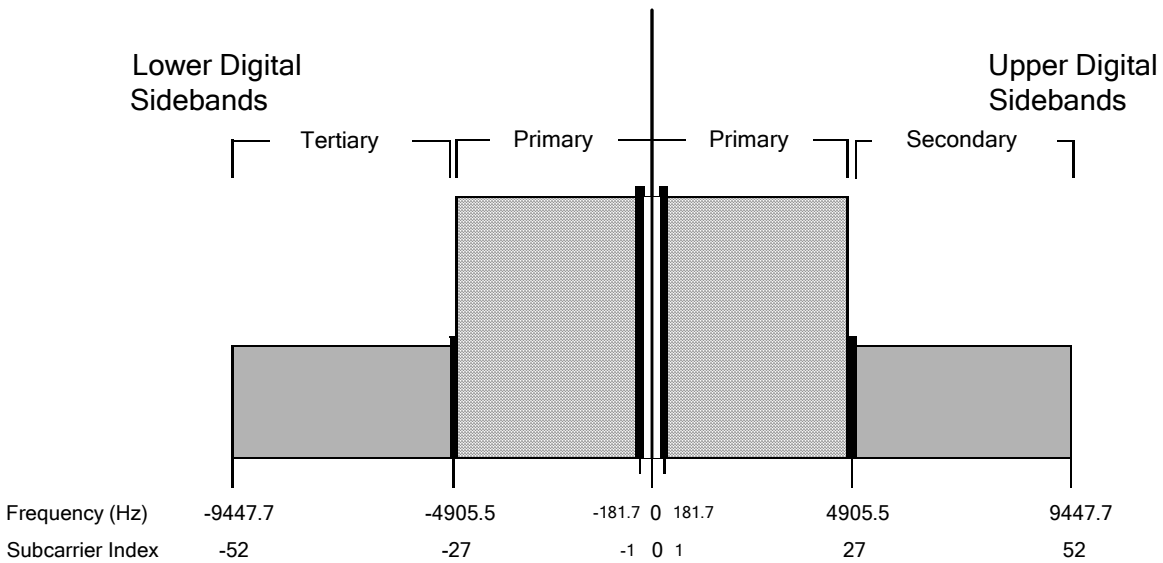

Figure 5-4: AM All Digital Waveform Spectrum

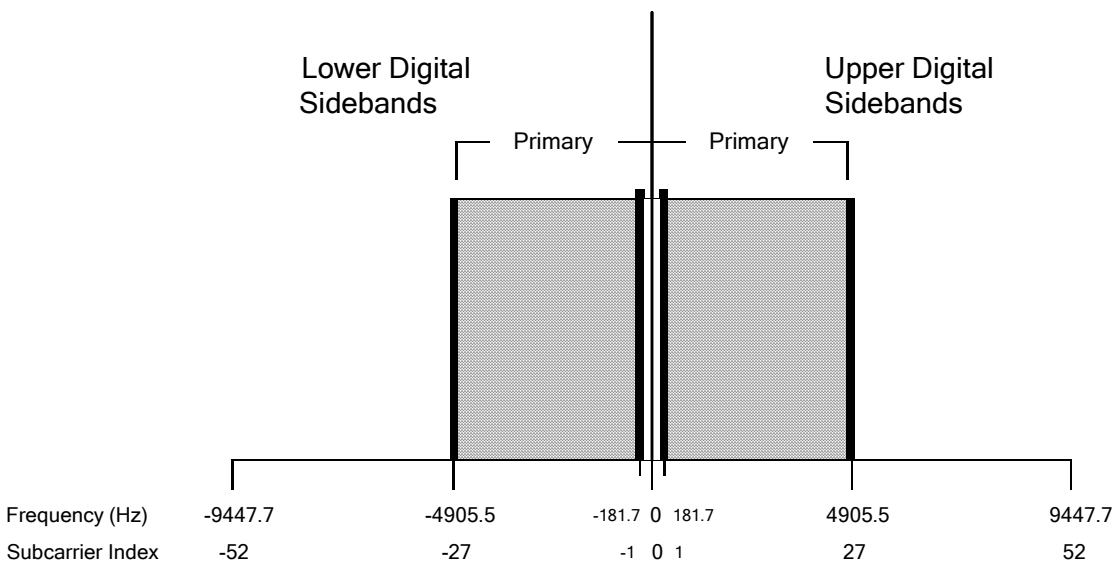

Figure 5-5: AM HD Radio All Digital Waveform Spectrum (Reduced Digital Bandwidth Configuration)

Table 5-2: AM All Digital Waveform Spectral Summary

Sideband	Subcarrier Range	Subcarrier Frequencies (Hz from channel center) <sup>‡</sup>	Amplitude Scale Factor	Comments
Primary Upper	2 to 26	363.4 to 4723.8	CD <sub>P</sub>	
Primary Lower	-2 to -26	-363.4 to -4723.8	CD <sub>P</sub>	
Secondary	28 to 52	5087.2 to 9447.7	CD <sub>E</sub> or 0.0	May be disabled by the control signal defined in Subsection 6.3.2
Tertiary	-28 to -52	-5087.2 to -9447.7	CD <sub>E</sub> or 0.0	May be disabled by the control signal defined in Subsection 6.3.2
Reference Upper	1	181.7	CD <sub>B</sub>	
Reference Lower	-1	-181.7	CD <sub>B</sub>	
PIDS1	27	4905.5	CD <sub>P</sub> · CD <sub>I1</sub> or CD <sub>P</sub> · CD <sub>I2</sub>	Power adjustable, relative to the Primary sideband power, as defined by the control signal settings defined in Subsection 6.3.
PIDS2	-27	-4905.5	CD <sub>P</sub> · CD <sub>I1</sub> or CD <sub>P</sub> · CD <sub>I2</sub>	Power adjustable, relative to the Primary sideband power, as defined by the control signal settings defined in Subsection 6.3.

<sup>‡</sup> Subcarrier frequencies shown refer to the center frequency of the subcarrier.



## 6 System Control Channel

### 6.1 Introduction

The SCCH passes discrete transfer frames of control and status information between Layer 2, the Configuration Administrator and Layer 1. The control information passed from the Configuration Administrator to Layer 1 consists of service mode control (PSM), power level control (PL) (for Hybrid waveforms only), reduced digital bandwidth control (RDB), high-power PIDS control (HPP), and *analog audio bandwidth control* (AAB) (for Hybrid waveforms only). In addition, several bits of the system control data sequence designated “reserved” are controlled by the Configuration Administrator.

The status information passed from Layer 1 to Layer 2 consists of *absolute L1 frame number* (ALFN) and *L1 block count* (BC). Refer to Figure 6-1. This status information and the L1 block count and indicators of the state of the control information (with the exception of ALFN) are broadcast on the reference subcarriers.

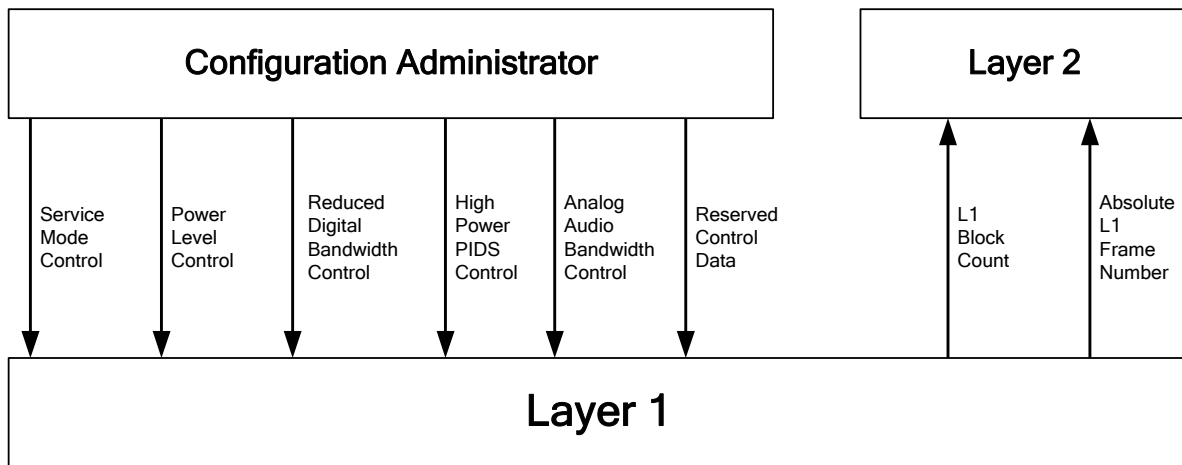

Figure 6-1: System Control Channel

The direction and rate of transfer between Layer 2, the Configuration Administrator and Layer 1 is given in Table 6-1.

Table 6-1: Transfer through the SCCH

Data	Direction	Transfer Frame Rate	Size (bits)
Service Mode Control (PSM)	Configuration Administrator ⇒ Layer 1	$R_f$	5
Power Level Control (PL)	Configuration Administrator ⇒ Layer 1	$R_f$	1
Reduced Digital Bandwidth Control (RDB)	Configuration Administrator ⇒ Layer 1	$R_f$	1
High-Power PIDS Control (HPP)	Configuration Administrator ⇒ Layer 1	$R_f$	1

Data	Direction	Transfer Frame Rate	Size (bits)
Analog Audio Bandwidth Control (AAB)	Configuration Administrator ⇒ Layer 1	R <sub>f</sub>	1
Reserved Control Data	Configuration Administrator ⇒ Layer 1	R <sub>f</sub>	5
L1 Block Count (BC)	Layer 1 ⇒ Layer 2	R <sub>b</sub>	4
Absolute L1 Frame Number (ALFN)	Layer 1 ⇒ Layer 2	R <sub>f</sub>	32

## 6.2 Service Mode Control

The service mode control determines the configuration and performance of the logical channels, as well as the waveform type (i.e., Hybrid or All Digital). The AM system as defined in this document supports two service modes: MA1 and MA3. MA1 is a Hybrid mode, while MA3 is an All Digital mode. Table 6-2 defines the bit assignments for the Service Mode Control.

Table 6-2: PSM Bit Assignments

Service Mode	Bit Assignment (Bits 4:0)
None	00000
MA1	00001
MA3	00010
Reserved	00011 - 11111

### 6.2.1 Service Mode Backward Compatibility

Service mode bit assignments greater than binary 00010 are reserved for future expansion. However, to ensure backward compatibility, all reserved service modes must maintain backward compatibility with one of the service modes MA1 and MA3. As a minimum, backward compatibility includes the PIDS logical channel, the system control data sequence (vector R) conveyed over the reference subcarriers, and at least one logical channel which can support medium-quality digital audio. Refer to Table 6-3 for a definition of the default service modes that first-generation receivers will assume and with which all transmission equipment must maintain backward compatibility for all reserved service mode assignments. Any service mode that is backward compatible with Hybrid service mode MA1 (e.g., MA6, MA10, MA14,...) is also a Hybrid service mode and includes the analog AM signal.

Table 6-3: Reserved Service Modes – Defaults

Actual Service Mode	Bit Assignment (Bits 4:0)	Default Service Mode	Backward Compatible Logical Channels/Elements	Logical Channels Free to be Redefined
MA4	000 11	Reserved	N/A	N/A
MA5	001 00	Reserved	N/A	N/A
MA6	001 01	MA1	P1, PIDS, <u>R</u> , Analog	P3

Actual Service Mode	Bit Assignment (Bits 4:0)	Default Service Mode	Backward Compatible Logical Channels/Elements	Logical Channels Free to be Redefined
MA7	001 10	MA3	P1, PIDS, <u>R</u>	P3
MA8	001 11	Reserved	N/A	N/A
MA9	010 00	Reserved	N/A	N/A
MA10	010 01	MA1	P1, PIDS, <u>R</u> , Analog	P3
MA11	010 10	MA3	P1, PIDS, <u>R</u>	P3
MA12	010 11	Reserved	N/A	N/A
MA13	011 00	Reserved	N/A	N/A
MA14	011 01	MA1	P1, PIDS, <u>R</u> , Analog	P3
MA15	011 10	MA3	P1, PIDS, <u>R</u>	P3
MA16	011 11	Reserved	N/A	N/A
MA17	100 00	Reserved	N/A	N/A
MA18	100 01	MA1	P1, PIDS, <u>R</u> , Analog	P3
MA19	100 10	MA3	P1, PIDS, <u>R</u>	P3
MA20	100 11	Reserved	N/A	N/A
MA21	101 00	Reserved	N/A	N/A
MA22	101 01	MA1	P1, PIDS, <u>R</u> , Analog	P3
MA23	101 10	MA3	P1, PIDS, <u>R</u>	P3
MA24	101 11	Reserved	N/A	N/A
MA25	101 00	Reserved	N/A	N/A
MA26	110 01	MA1	P1, PIDS, <u>R</u> , Analog	P3
MA27	110 10	MA3	P1, PIDS, <u>R</u>	P3
MA28	110 11	Reserved	N/A	N/A
MA29	111 00	Reserved	N/A	N/A
MA30	111 01	MA1	P1, PIDS, <u>R</u> , Analog	P3
MA31	111 10	MA3	P1, PIDS, <u>R</u>	P3
MA32	111 11	Reserved	N/A	N/A

### 6.2.2 Service Mode Switching

The service mode control is received from the Configuration Administrator via the SCCH at the rate  $R_f$ . Service mode changes are invoked only on an *L1 frame* boundary (see Subsection 6.3).

### 6.3 Subcarrier Scaling Control Signals

The system provides three control signals, RDB, HPP, and PL that determine the power profile of the various sidebands. These three controls are received from the Configuration Administrator at the *L1 frame rate*,  $R_f$ , and any change can be effected directly at an L1 frame boundary upon receipt without interrupting service. Table 6-4 and Table 6-5 show the amplitude scale factor selections versus the states of the subcarrier scaling control signals for service modes MA1 and MA3, respectively.

Refer to Subsections 6.3.1, 6.3.2, and 6.3.3 for detailed descriptions of the RDB, HPP, and PL control signals, respectively. Each of these control signals has a corresponding indicator that is broadcast in the system control data sequence, as described in Subsection 11.2. Refer to [9] for details on the actual power levels associated with the amplitude scale factors shown in Table 6-4 and Table 6-5.

Table 6-4: Subcarrier Scaling Control Signal States for Service Mode MA1

Subcarrier Scaling Control Signal State			Amplitude Scale Factor Selection				Comments
RDB	HPP	PL	PIDS2 / PIDS2*	PIDS1 / PIDS1*	Secondary	Tertiary	
0	0	0	CH <sub>PU</sub> · CH <sub>I3</sub> CH <sub>PL</sub> · CH <sub>I3</sub>	CH <sub>I1</sub>	CH <sub>S1</sub>	CH <sub>T1</sub> [0:24]	Standard Power Profile: Low-power Secondary/Tertiary/PIDS1 Low-power PIDS2
0	0	1	CH <sub>PU</sub> · CH <sub>I4</sub> CH <sub>PL</sub> · CH <sub>I4</sub>	CH <sub>I2</sub>	CH <sub>S2</sub>	CH <sub>T2</sub> [0:24]	High-power Secondary/Tertiary/PIDS1 Medium-power PIDS2
0	1	0	CH <sub>PU</sub> · CH <sub>I5</sub> CH <sub>PL</sub> · CH <sub>I5</sub>	CH <sub>I1</sub>	CH <sub>S1</sub>	CH <sub>T1</sub> [0:24]	Low-power Secondary/Tertiary/PIDS1 High Power PIDS2
0	1	1	CH <sub>PU</sub> · CH <sub>I5</sub> CH <sub>PL</sub> · CH <sub>I5</sub>	CH <sub>I2</sub>	CH <sub>S2</sub>	CH <sub>T2</sub> [0:24]	High-power Secondary/Tertiary/PIDS1 High Power PIDS2
1	X	X	CH <sub>PU</sub> · CH <sub>I5</sub> CH <sub>PL</sub> · CH <sub>I5</sub>	0.0	0.0	0.0	Secondary/Tertiary/PIDS1 are disabled High Power PIDS2

Table 6-5: Subcarrier Scaling Control Signal States for Service Mode MA3

Subcarrier Scaling Control Signal State			Amplitude Scale Factor Selection		Comments
RDB	HPP	PL	PIDS2 / PIDS1	Secondary / Tertiary	
0	0	X	CD <sub>P</sub> · CD <sub>I1</sub>	CD <sub>E</sub>	Standard Power Profile
0	1	X	CD <sub>P</sub> · CD <sub>I2</sub>	CD <sub>E</sub>	High-Power PIDS
1	X	X	CD <sub>P</sub> · CD <sub>I2</sub>	0.0	Secondary/Tertiary Sidebands Disabled High Power PIDS

### 6.3.1 Power Level Control

In the Hybrid waveform, the nominal level of the secondary, PIDS1, and tertiary sidebands is one of two selectable values: low or high. Power level control (PL) specifies which level is to be employed. When PL is a logical 0 (low power level), the Hybrid subcarriers are scaled by  $CH_{S1}$ ,  $CH_{I1}$ , and  $CH_{T1}$  to increase digital coverage. When PL is a logical 1 (high power level), the Hybrid subcarriers are scaled by  $CH_{S2}$ ,  $CH_{I2}$ , and  $CH_{T2}$  to reduce analog interference. Refer to [9] for details. When transmitting the All Digital waveform, PL is ignored.

When RDB is set to 1, the state of the PL control signal is ignored.

### 6.3.2 Reduced Digital Bandwidth Control

The *Reduced Digital Bandwidth Control* (RDB) is used to limit the spectrum of the MA1 and MA3 waveforms. In service mode MA1, RDB may be used to reduce interference to the analog host and accommodate an analog bandwidth of up to 9.4 kHz. In service mode MA3, RDB may be used to reduce interference to adjacent channels.

When RDB is 0 (standard configuration), the secondary and tertiary sidebands are enabled, and the PIDS subcarriers are all active.

When RDB is 1 (reduced bandwidth configuration), the secondary and tertiary sidebands are disabled by setting the appropriate amplitude scale factors to zero. In addition, for service mode MA1, the PIDS1 and PIDS1\* subcarriers are disabled. In both service modes MA1 and MA3, setting RDB to 1 will set the active PIDs subcarriers to the high-power configuration.

When RDB is set to 1, the state of the PL and HPP control signals is ignored.

### 6.3.3 High-Power PIDS Control

The High Power PIDS Control (HPP) is used to set the level of the PIDS2/PIDS2\* subcarriers in service mode MA1 and the PIDS1/PIDS2 subcarriers in service mode MA3. If HPP is 0, these PIDS subcarriers will be in the standard low-power configuration. If HPP is 1, these PIDS subcarriers will be in the high-power configuration.

When RDB is set to 1, the state of the HPP control signal is ignored.

## 6.4 Analog Audio Bandwidth Control

In the standard configuration ( $RDB = 0$ ) of the hybrid waveform, the bandwidth of the analog audio is one of two selectable values: 5 kHz or 8 kHz. Analog audio bandwidth control (AAB) specifies which bandwidth is to be employed. When AAB is a logical 0, the bandwidth indicated is 5 kHz. When AAB is a logical 1, the bandwidth indicated is 8 kHz. When transmitting the All Digital waveform, it is ignored. Analog audio bandwidth control is received from the Configuration Administrator at the L1 frame rate,  $R_f$ , and any change can be effected directly (at an L1 frame boundary) upon receipt without interrupting service. Digital coverage of a Hybrid station (primary subcarriers only) is adversely impacted by a second adjacent Hybrid transmission with 8 kHz audio bandwidth.

In the reduced digital bandwidth configuration ( $RDB = 1$ ) of the hybrid waveform, the state of AAB is not applicable and shall be set to a value of zero.

## 6.5 Absolute L1 Frame Number

The transmitted HD Radio signal may be regarded as a series of unique L1 frames of duration  $T_f$ . In order to reference all transmissions to absolute time, each L1 frame is associated with an ALFN. This universal frame numbering scheme assumes that the start of ALFN 0 occurred at the GPS epoch -00:00:00 Coordinated Universal Time (UTC) on January 6, 1980. The start of every subsequent L1 frame occurs at an exact integer multiple of  $T_f$  after that instant in time. A new GPS epoch starts every 1024 weeks. The current ALFN is a binary number determined by subtracting the GPS start time (00:00:00 on January 6, 1980) from the current GPS time (making allowance for the GPS epoch), expressing the difference in seconds, and multiplying the result by the frame rate,  $R_f$ .

The ALFN, which is passed to Layer 2 via the SCCH at the rate  $R_f$ , is used to schedule the delivery of time-critical programming. It is not broadcast as part of the transmitted HD Radio signal.

## 6.6 L1 Block Count

Each L1 frame may be considered to consist of eight *L1 blocks* of duration  $T_b$ . The BC indicates the position of the current L1 block within the L1 frame. An L1 block count of 0 signifies the start of an L1 frame, while a BC of 7 designates the final L1 block in an L1 frame. Table 6-6 defines the bit assignments for the L1 Block Count passed to L2.

The three least significant bits of BC are passed to Layer 2 via the SCCH at the rate  $R_b$ . They are broadcast on the reference subcarriers and are used by the receiver to aid in synchronization. The most significant bit of BC is not used. An illustration of the relationship of L1 blocks to L1 frames is shown in Figure 6-2.

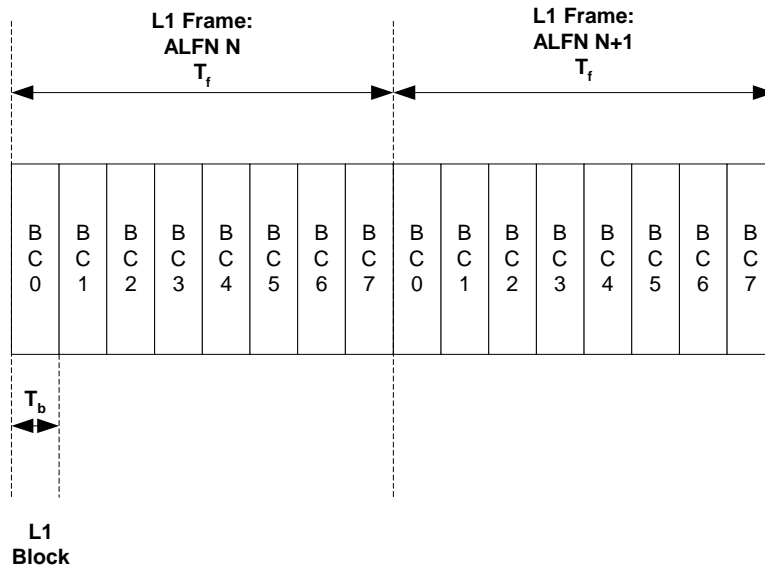

Figure 6-2: L1 Frames and Blocks

Table 6-6: BC Bit Assignments

L1 Block Count	BC Bit Assignment (Bits 3:0)
0	0000
1	0001
2	0010
3	0011
4	0100
5	0101
6	0110
7	0111
Not Used	1000 - 1111

## 7 Logical Channels

### 7.1 Introduction

A logical channel is a signal path that conducts L2 PDUs through Layer 1 with a specified grade of service. The available logical channels are P1, P3, and PIDS. Logical channels are defined by their characterization parameters and configured by the service mode. They are used in both the Hybrid and All Digital waveforms.

### 7.2 Characterization Parameters

For a given service mode, the grade of service of a particular logical channel may be uniquely quantified using three characterization parameters: transfer, latency, and robustness. Channel code rate, interleaver depth, digital diversity delay, and spectral mapping are the determinants of the characterization parameters.

#### 7.2.1 Transfer

The throughput of a logical channel is called transfer. The block-oriented operations of Layer 1 (such as interleaving) require that data be processed in discrete transfer frames rather than continuous streams. As a result, throughput is defined in terms of *transfer frame size* (in bits) and *transfer frame rate* (in Hz, or the number of transfer frames per second). This Layer 1 framing effectively defines the alignment of L2 PDUs.

Each transfer frame is uniquely identified by its *transfer frame number*  $F_{m1:m2}^n$ , where n is the ALFN with which the transfer frame is associated and m1:m2 is the *BC range* that is spanned by the transfer frame within the L1 frame n. Thus, the BC range indicates the position of the transfer frame within the L1 frame. In cases where a transfer frame is split and delayed in L1 with the result that it is transmitted in two different ALFNs, the superscript n refers to the first instance of its transmission. The transfer frame number is not broadcast as part of the transmitted HD Radio signal.

All transfer frames are conducted through Layer 1 at one of two rates:

- the L1 frame rate,  $R_f = \frac{1}{T_f}$
- the L1 block rate,  $R_b = \frac{1}{T_b}$

The transfer frame rate relationships are summarized in Table 7-1 and illustrated in Figure 7-1.

Table 7-1: Transfer Frame Rate Relationships

Transfer Frame		
Type	Duration (Seconds)	Rate (Hz)
L1 block	$T_b$	$R_b = 8 \cdot R_f$
L1 frame	$T_f$	$R_f$



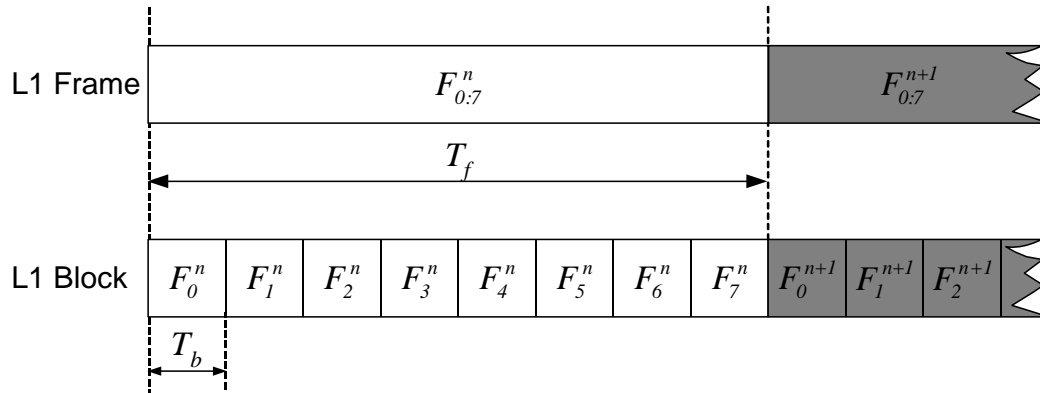

Figure 7-1: Transfer Frame Timing Relationships

Spectral mapping and channel code rate determine the transfer of a logical channel, since spectral mapping limits capacity and coding overhead limits information throughput. Interleaver depth is also a factor, because transfer frames are conducted through Layer 1 at rates corresponding to the interleaver depth of their logical channel.

### 7.2.2 Latency

Latency is the delay that a logical channel imposes on a transfer frame as it traverses Layer 1. The latency of a logical channel is defined as the sum of its interleaver depth and digital diversity delay. It does not include processing delays in Layer 1 nor does it include delays imposed in upper layers.

The interleaver depth determines the amount of delay imposed on a logical channel by an interleaver. The AM HD Radio system employs two interleaver depths: L1 block and L1 frame. A digital diversity delay of  $T_{dd}$  is also employed on some logical channels, such as P1 in service mode MA1, for example.

Higher layers assign information to logical channels with the requisite latency through service mode selection. Three latencies are specified for the system, as defined in Table 7-2.

Table 7-2: Latency Summary

Description	Delay
L1 block	$T_b$
L1 frame	$T_f$
L1 frame plus digital diversity delay	$T_f + T_{dd}$

### 7.2.3 Robustness

Robustness is the ability of a logical channel to withstand channel impairments such as noise, interference, and *grounded conductive structures* (GCS). There are eight relative levels of robustness designed into Layer 1 of the AM air interface. A robustness of 1 indicates a very high level of resistance to channel impairments, while a robustness of 8 indicates a lower tolerance for channel-induced errors. As with latency, higher layers must determine the required robustness of a logical channel before selecting a service mode.

Spectral mapping, channel code rate, interleaver depth, the power level of each sideband, and digital diversity delay determine the robustness of a logical channel. Spectral mapping affects robustness by

setting the relative power level, spectral interference protection, and frequency diversity of a logical channel. Channel coding increases robustness by introducing redundancy into the logical channel. Interleaver depth influences performance in *fading*, thereby affecting the robustness of the logical channel. Reducing the power of one or both primary sidebands will have a commensurate impact on robustness.

Finally, some logical channels in certain service modes delay transfer frames by a fixed duration to realize time diversity. This digital diversity delay also affects robustness, since it mitigates the effects of the mobile radio channel.

#### 7.2.4 Assignment of Characterization Parameters

Table 7-3 and Table 7-4 show the characterization parameters of each logical channel for every service mode. Transfer is presented in terms of transfer frame size and transfer frame rate. The relative robustness figures are approximate. Exact performance may vary depending on the specific channel conditions as well as individual sideband power. The robustness figures provided in the following tables assume equal power levels in each primary sideband.

Table 7-3: Logical Channel Characterization – Service Mode MA1

Logical Channel	Transfer			Relative Robustness
	Frame Size (Bits)	Frame Rate (Hz)	L1 Latency (s)	
P1	3750	$R_b$	$T_f + T_{dd}$	5
P3	24000	$R_f$	$T_f$	6 (PL=High) or 8 (PL=Low)
PIDS	80	$R_b$	$T_b$	3 (PL=High) or 7 (PL=Low)

Table 7-4: Logical Channel Characterization – Service Mode MA3

Logical Channel	Transfer			Relative Robustness
	Frame Size (Bits)	Frame Rate (Hz)	L1 Latency (s)	
P1	3750	$R_b$	$T_f + T_{dd}$	1
P3	30000	$R_f$	$T_f + T_{dd}$	4
PIDS	80	$R_b$	$T_b$	2

Information throughput of a logical channel can be calculated using these tables and the following formula:

$$\text{throughput (bits/s)} = \text{transfer frame size (bits)} \cdot \text{transfer frame rate (Hz)}$$

For example, in service mode MA1, the throughput for logical channel P1 is calculated as follows:

$$\text{throughput} = 3750 \cdot (8 \cdot 44100/65536) \approx 20.2 \text{ kbits/s}$$

### 7.3 Spectral Mapping

For a given service mode, each logical channel is applied to a frequency sideband. Figure 7-2 through Figure 7-5 show the spectral mapping for each logical channel for every service mode. In these figures, the annotated frequencies represent offsets from the channel center frequency.

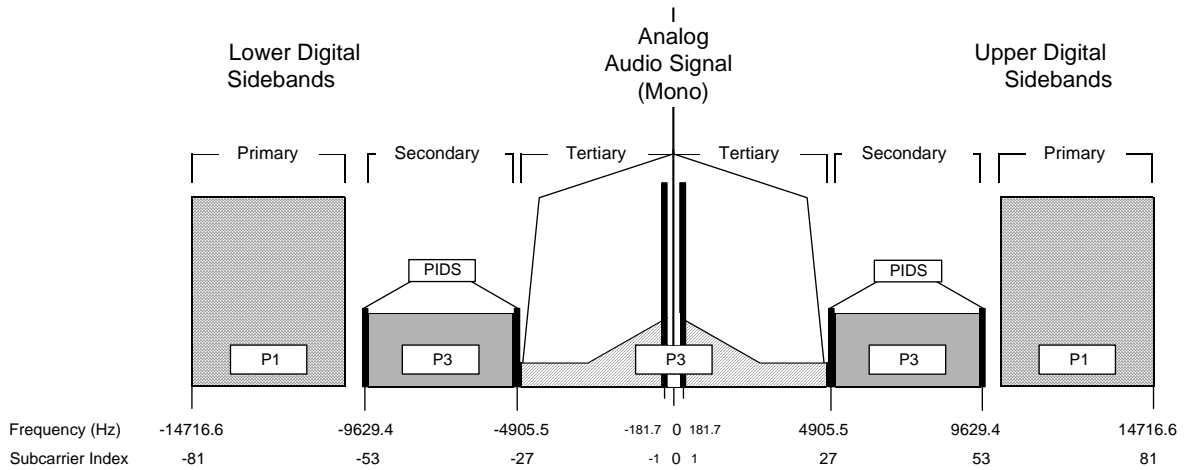

Figure 7-2: Logical Channel Spectral Mapping – Service Mode MA1 (5 kHz Audio Configuration)

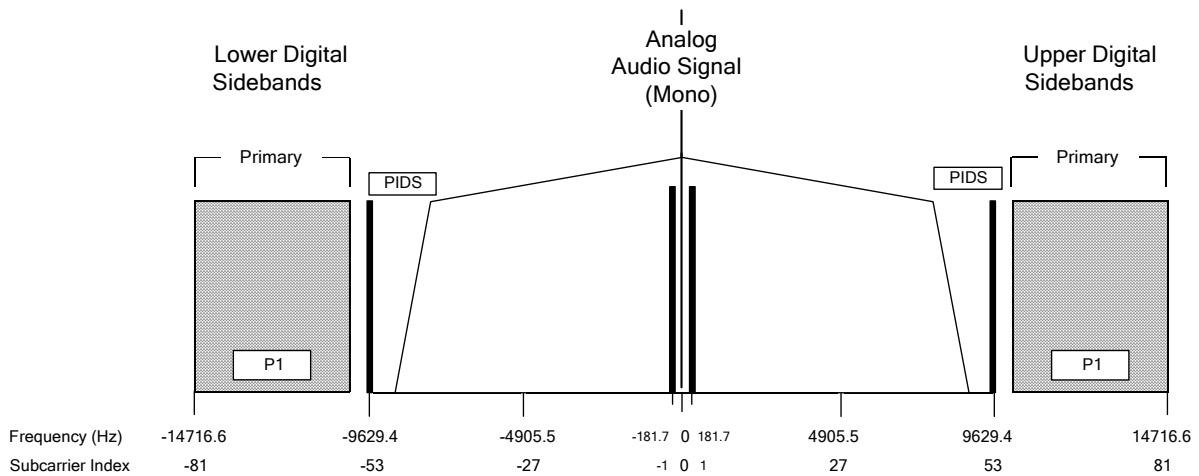

Figure 7-3: Logical Channel Spectral Mapping – Service Mode MA1 (Reduced Digital Bandwidth Configuration)

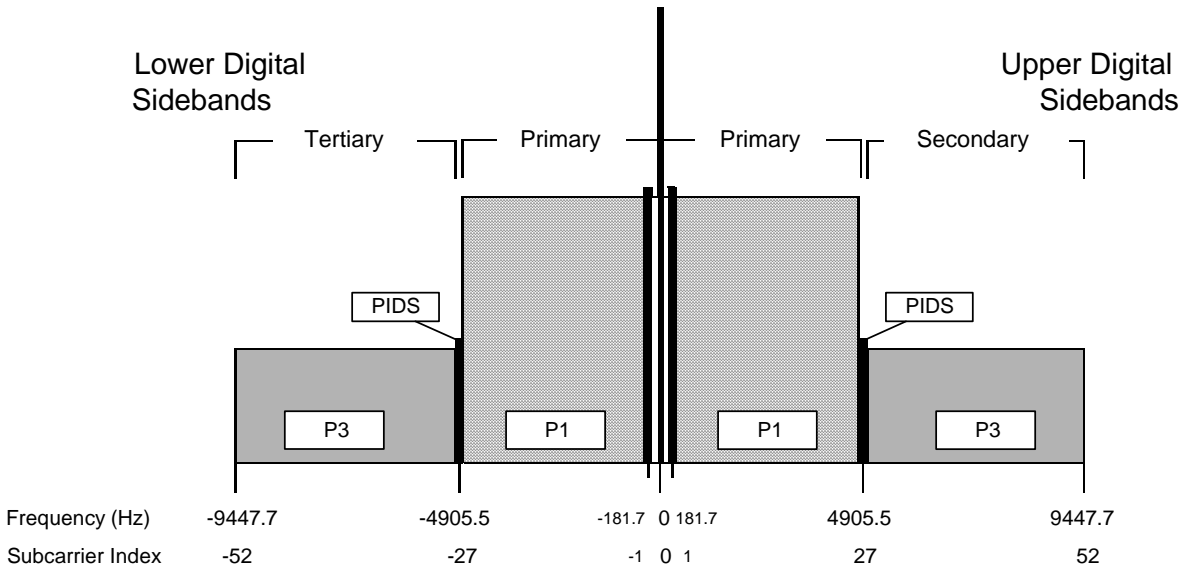

Figure 7-4: Logical Channel Spectral Mapping – Service Mode MA3

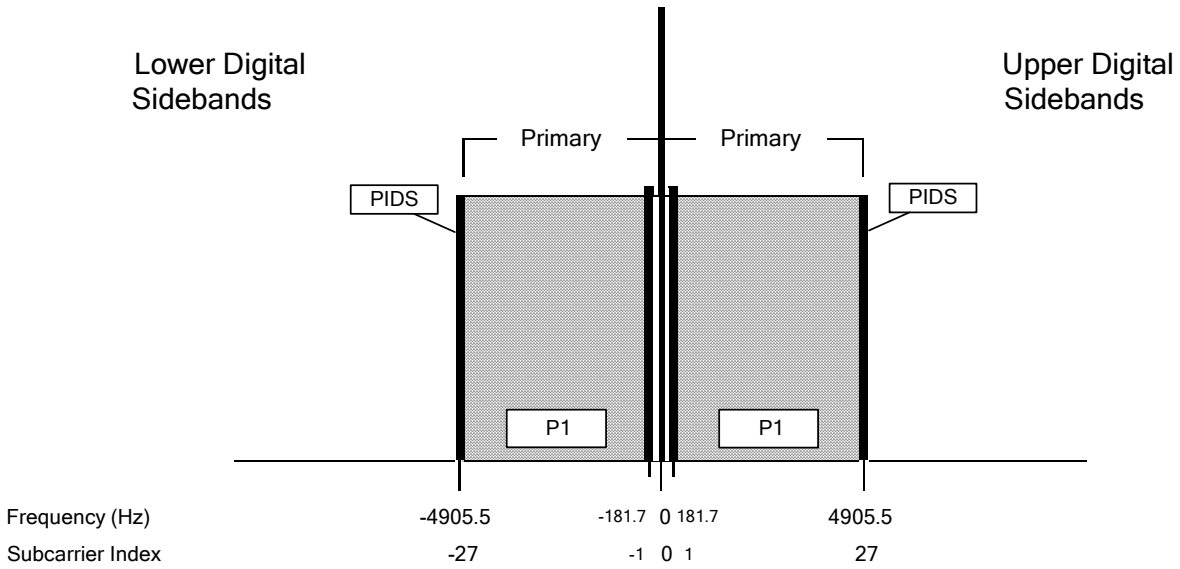

Figure 7-5: Logical Channel Spectral Mapping – Service Mode MA3 (Reduced Digital Bandwidth Configuration)

## 7.4 Framing and Synchronization

The logical channels share a common, absolute time reference so that all transfer frames are precisely aligned. As described in Subsection 7.2.1, each transfer frame is assigned a unique transfer frame number  $F_{m1:m2}^n$ , where n is the ALFN, and m1:m2 is the BC range that designates the position of the transfer frame within the indexed L1 frame. This numbering scheme allows all transfer frames to be referenced to an absolute transmission time. Further details of system timing alignment are given in Section 14.

## 8 Scrambling

The bits in each logical channel are scrambled to randomize the time-domain data and aid in receiver synchronization. As shown in Figure 8-1, there are three parallel scramblers, one for each logical channel.

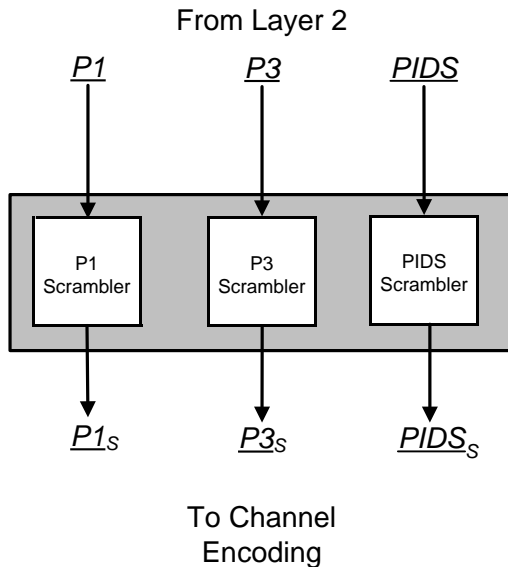

Figure 8-1: Scrambling Functional Block Diagram

The inputs to the scramblers are the active logical channels from Layer 2, as selected by the service mode control. These inputs are delivered in discrete transfer frames whose size and rate are defined in Table 7-3 and Table 7-4 for a given service mode. The outputs of the scramblers are transfer frames of scrambled bits for each of the active logical channels. These transfer frames are passed to the channel encoding process for forward error correction.

### 8.1 Scrambler Operation

All parallel scramblers are identical but operate at different rates, depending upon the active service mode. A detailed block diagram of the scrambler is shown in Figure 8-2. Each scrambler generates a maximal-length scrambling sequence using a linear feedback shift register with the following primitive polynomial:  $P(x) = 1 \oplus x^2 \oplus x^{11}$ . A given bit of a scrambled transfer frame is generated by modulo-2 adding the associated input bit with the corresponding bit of the scrambling sequence.

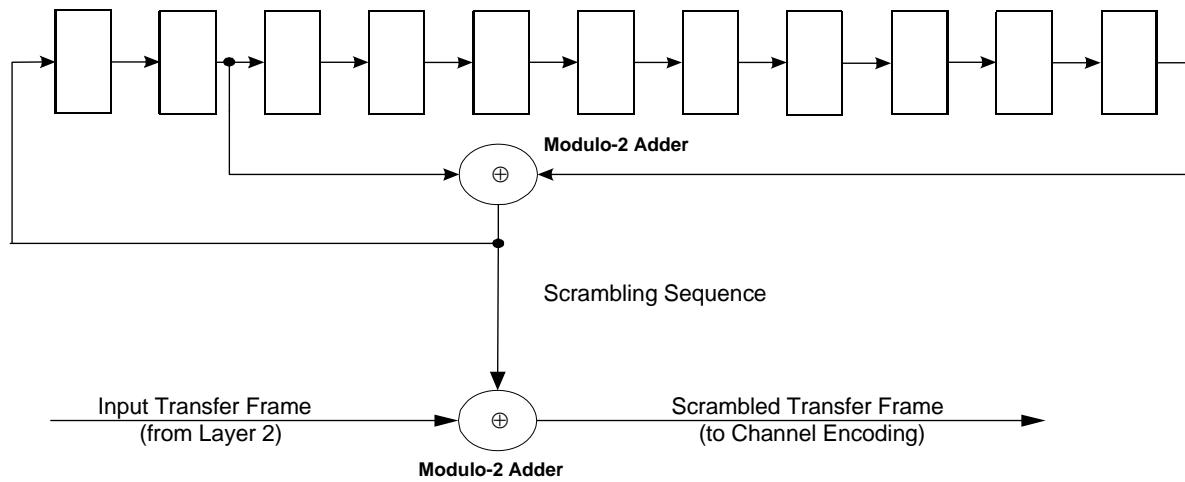

Figure 8-2: Scrambler Block Diagram

For each logical channel, the scrambler is reset to state 0111 1111 111 upon receipt of a new transfer frame. The first bit of a scrambled transfer frame is generated by modulo-2 adding the first bit of the input transfer frame with the scrambling bit generated when the shift register is set to the initial state. The process then continues until the last bit of the input transfer frame is scrambled.

## 9 Channel Encoding

Channel encoding improves system performance by increasing the robustness of the signal in the presence of interference and channel impairments. As shown in Figure 9-1, the channel encoding process is characterized by the single operation of convolutional encoding.

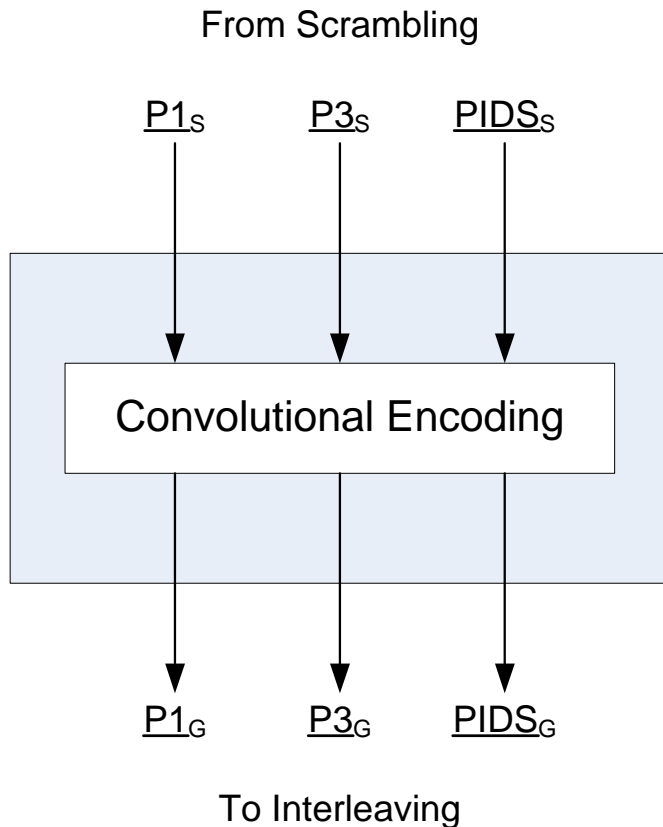

Figure 9-1: Channel Encoding Functional Block Diagram

The inputs to the channel encoding process are transfer frames of scrambled bits carried through the active logical channels. The size and rate of transfer are defined in Table 7-3 and Table 7-4 for a given service mode. The outputs of the channel encoding process are transfer frames of encoded bits associated with each of the active logical channels and are passed to interleaving.

In the ensuing subsections, for notational convenience, the logical channel vectors at a particular stage of processing are represented in shorthand notation by their subscript. For example, the scrambled inputs  $P1_s$ ,  $P3_s$ , and  $PIDS_s$  are represented by  $\underline{S}$ , while the encoded outputs  $P1_G$ ,  $P3_G$ , and  $PIDS_G$  are represented by  $\underline{G}$ .



## 9.1 Convolutional Encoding

Convolutional encoding consists of three primary operations: *mother code* generation, *puncturing*, and parallel-to-serial conversion. Each of these operations is described below.

### 9.1.1 Mother Code Generation

The convolutional encoders associated with each logical channel employ select generator polynomials to form a rate 1/3 mother code. Each convolutional encoder outputs 3 encoded bits  $g_{h,i}$  for every input bit  $s_i$ ,  $i=0,1,2,\dots,N-1$ , creating a codeword matrix  $\underline{\underline{G}}$  of dimension 3 x N:

$$\underline{\underline{G}} = \begin{bmatrix} g_{1,0} & g_{1,1} & \cdots & g_{1,N-1} \\ g_{2,0} & g_{2,1} & \cdots & g_{2,N-1} \\ g_{3,0} & g_{3,1} & \cdots & g_{3,N-1} \end{bmatrix}$$

where  $N$  is the length of  $\underline{\underline{S}}$ , and  $h=1,2,3$  indexes the codeword bits for a given input information bit. Each column of  $\underline{\underline{G}}$  represents the encoded output for a given input bit.

### 9.1.2 Puncturing

Most service modes require puncturing of the mother codeword to produce a slightly higher code rate, thereby allowing a higher information rate through the same physical bandwidth. The codeword matrix  $\underline{\underline{G}}$  is punctured over a puncture period  $P$ . For every  $P$  encoded bits, certain bits  $g_{h,i}$  are not transmitted. A puncture matrix spanning the encoded bits over a puncture period defines which encoded bits are transmitted. A puncture pattern is formed by repeating the puncture matrix over all information bits in the transfer frame.

### 9.1.3 Parallel-to-Serial Conversion

After the mother code bits are appropriately punctured, the parallel-to-serial converter multiplexes them by concatenating the columns of  $\underline{\underline{G}}$  into a single vector  $\underline{\underline{G}}$ .

### 9.1.4 Convolutional Encoders

Table 9-1 presents the three code rates used in the AM system, along with their associated puncture matrices. The codes are designated E1, E2, and E3. The last 8 bits of a given transfer frame are used to initialize the delay elements of the corresponding convolutional encoder for that transfer frame.

Table 9-1: AM Convolutional Codes

Encoder	Punctured Code Rate	Puncture Matrix	Mother Code Rate
E1	5/12	$\begin{bmatrix} 1 & 1 & 1 & 1 & 1 \\ 0 & 0 & 0 & 1 & 1 \\ 1 & 1 & 1 & 1 & 1 \end{bmatrix}$	1/3
E2	2/3	$\begin{bmatrix} 1 & 1 & 1 & 1 \\ 0 & 0 & 0 & 0 \\ 1 & 0 & 1 & 0 \end{bmatrix}$	1/3

E3	1/3	$\begin{bmatrix} 1 \\ 1 \\ 1 \end{bmatrix}$	1/3
----	-----	---	-----

### 9.1.4.1 E1 Convolutional Encoder

The E1 convolutional encoder, illustrated in Figure 9-2, uses a constraint length 9 rate 1/3 mother code punctured to rate 5/12. The generator polynomial used is represented in Table 9-2 below. This code is represented in octal format.

Table 9-2: E1 Convolutional Encoder Generator Polynomials – Rate 1/3 Mother Code

First Generator	Second Generator	Third Generator
561	657	711

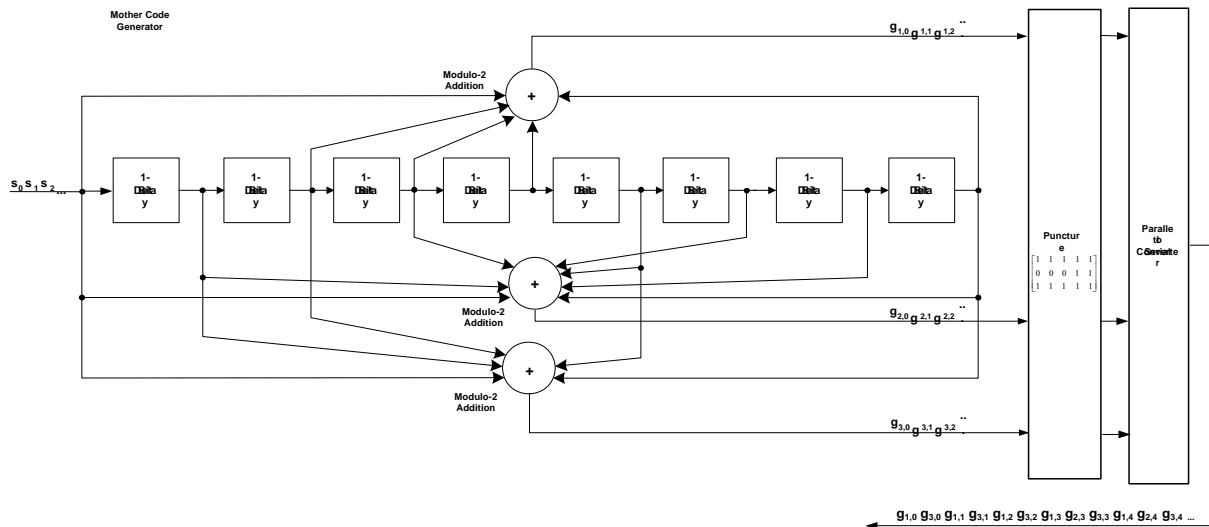

Figure 9-2: E1 Convolutional Encoder

### 9.1.4.2 E2 Convolutional Encoder

The E2 convolutional encoder, illustrated in Figure 9-3, uses a constraint length 9 rate 1/3 mother code punctured to rate 2/3. The generator polynomial used is represented in Table 9-3. This code is represented in octal format.

Table 9-3: E2 Convolutional Encoder Generator Polynomials

First Generator	Second Generator	Third Generator
561	753	711

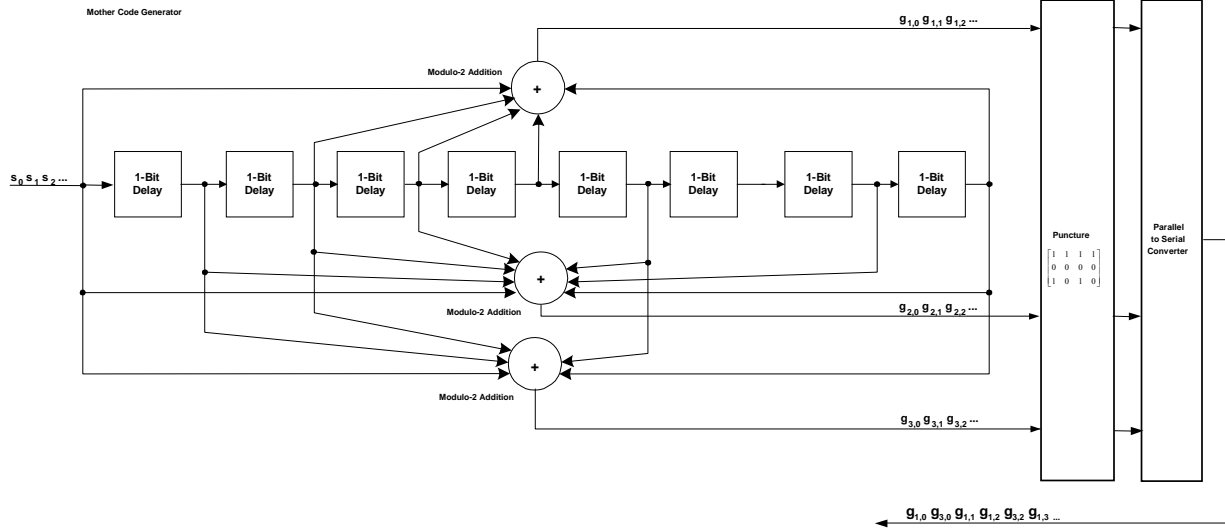

Figure 9-3: E2 Convolutional Encoder

### 9.1.4.3 E3 Convolutional Encoder

The E3 convolutional encoder, illustrated in Figure 9-4, uses a constraint length 9 rate 1/3 un-punctured mother code. The general polynomial used is represented in octal format as shown in Table 9-4.

Table 9-4: E3 Convolutional Encoder Generator Polynomials

First Generator	Second Generator	Third Generator
561	753	711

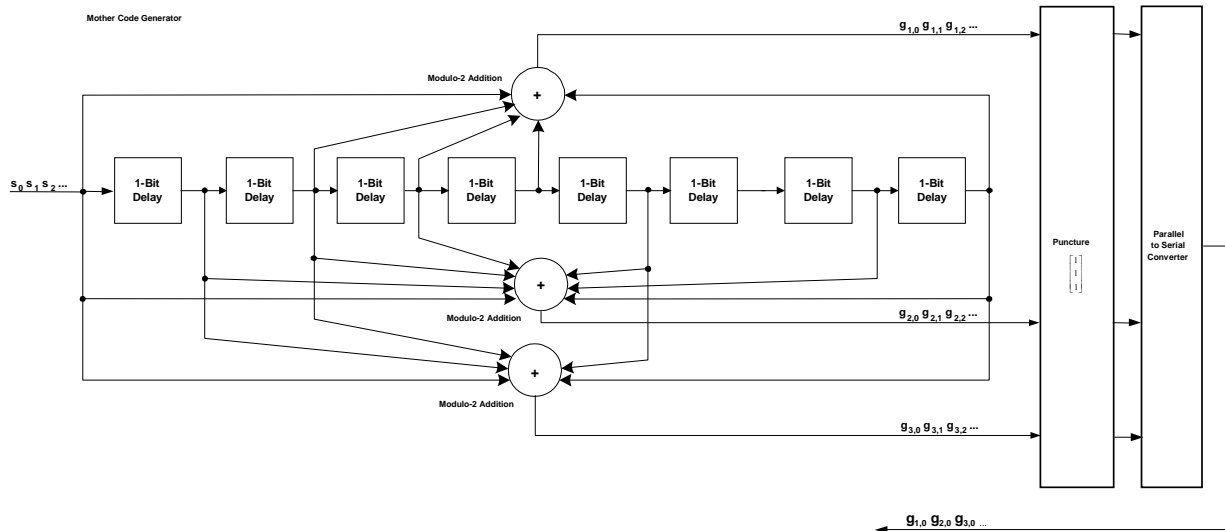

Figure 9-4: E3 Convolutional Encoder

## 9.2 Channel Encoding Data Flow

The channel encoding process for each logical channel in each service mode is specified in Subsection 9.2.1 through Subsection 9.2.2.

### 9.2.1 Service Mode MA1

The P1, P3, and PIDS logical channels are active in service mode MA1. The flow of their transfer frames through the channel encoding process is shown in Figure 9-5.

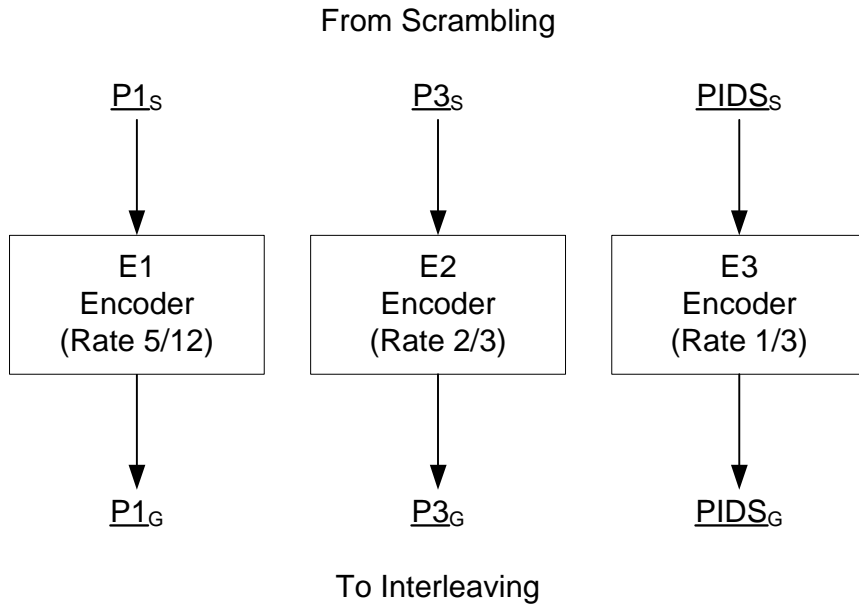

Figure 9-5: Channel Encoding – Service Mode MA1

9.2.2 Service Mode MA3

The P1, P3, and PIDS logical channels are active in service mode MA3. The flow of their transfer frames through the channel encoding process is shown in Figure 9-6.

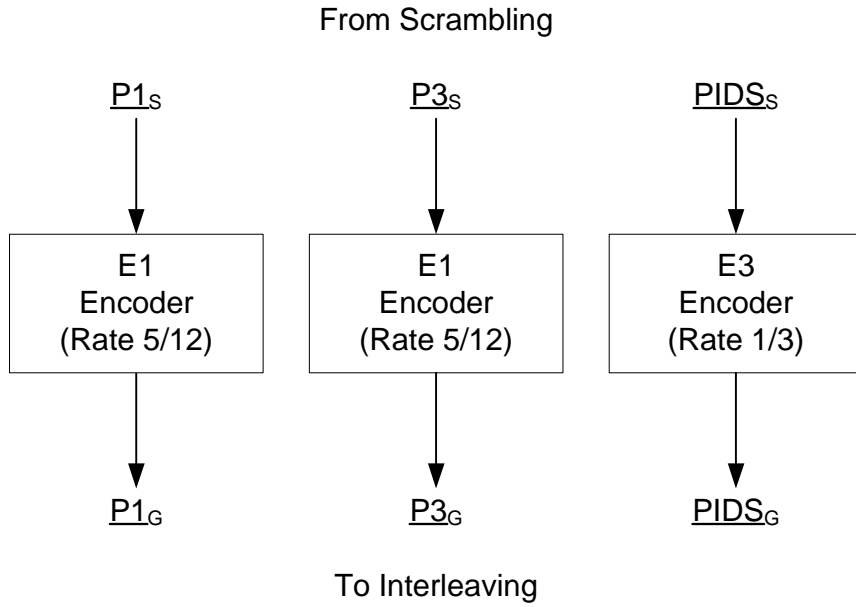

Figure 9-6: Channel Encoding – Service Mode MA3

## 10 Interleaving

### 10.1 Introduction

Interleaving provides both time and frequency diversity. As shown in Figure 10-1, interleaving for the AM system is characterized by four primary operations: *subframe generation*, *digital diversity delay*, *transmit time alignment*, and *bit mapping*.

Subframe generation is the process of accumulating the bits of one or more transfer frames and splitting them into subframes as an initial step in assigning data to the various interleaver matrices. Digital diversity delay is the process of adding delay to a select group of subframes for the purpose of adding additional time diversity beyond that provided by the interleaver matrices. *Transmit time alignment*,  $T_{T1a}$ , is associated with the P1 logical channel and allows more flexibility in the transfer of this data. It is adjusted to provide a digital diversity delay between main and backup streams to achieve precisely  $T_{dd}$ . The bit mapping process assigns each subframe bit to a row and column in an interleaver matrix as well as to a unique bit position in the digital word within the interleaver matrix element.

The manner in which the logical channels are split into subframes, delayed and mapped into interleaver matrices, is shown in Figure 10-4 through Figure 10-6 for each logical channel in each service mode.

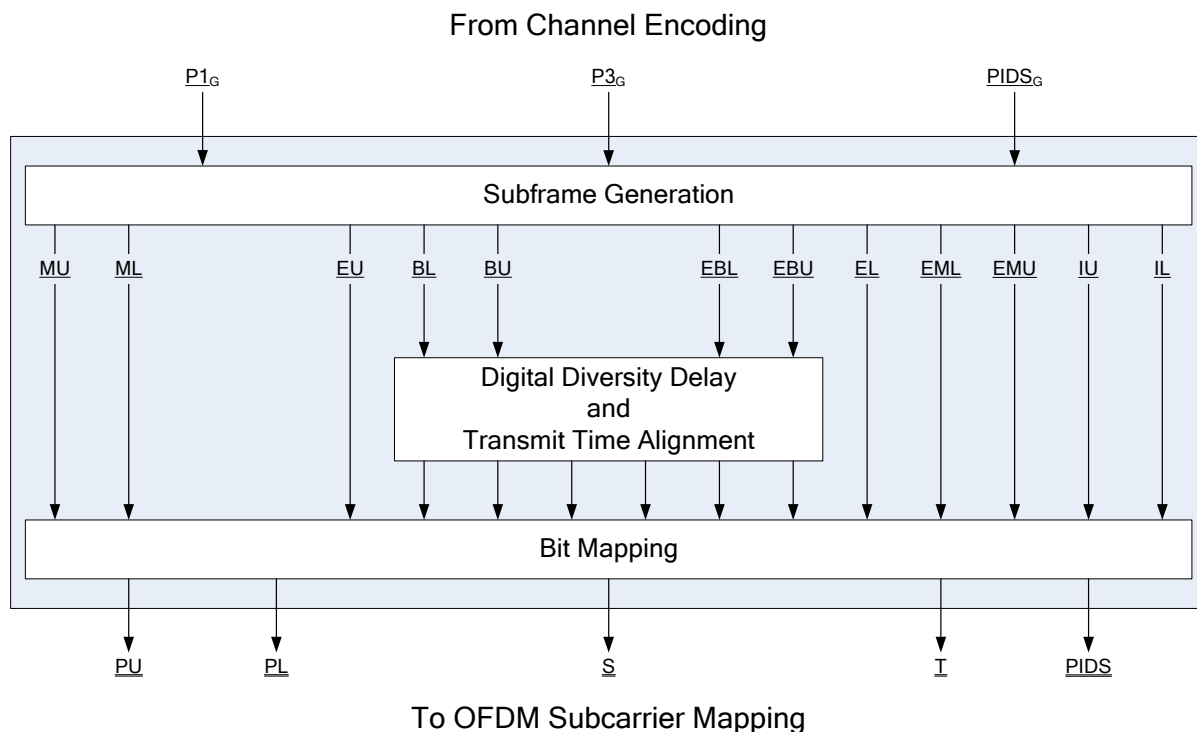

Figure 10-1: Interleaving Conceptual Block Diagram

The inputs to interleaving are the transfer frame vectors for each logical channel output from channel encoding. Table 10-1 and Table 10-2 define the size and rate of the transfer frames on each active logical channel, along with the destination interleaver matrix and the number of transfer frames required to fill the destination interleaver matrix. The output interleaver matrices are passed to OFDM Subcarrier Mapping, which maps a row from each interleaver matrix to its respective upper and lower sidebands.

Some of the interleaver matrices require more than one transfer frame to fill all of their elements. These transfer frames must be buffered until enough have been accumulated to fill the entire interleaver matrix.

In service mode MA1, eight  $P1_G$  transfer frames are required to fill the  $\underline{PU}$  and  $\underline{PL}$  interleaver matrices. Each  $P1_G$  transfer frame is delivered from Layer 2 to Layer 1 at the L1 block rate  $R_b$ . These transfer frames are buffered in subframe generation and processed at the L1 frame rate  $R_f$ . One  $P3_G$  transfer frame is required to fill the  $\underline{S}$  and  $\underline{T}$  interleaver matrices. It is delivered from Layer 2 to Layer 1 at the L1 frame rate. To fill the  $\underline{PIDS}$  interleaver matrix,  $\underline{PIDS}_G$  transfer frames are not buffered, but are processed at the L1 block rate.

Similar relationships for service mode MA3 can be observed in Table 10-2.

Table 10-1: Transfer Frame Characteristics – Service Mode MA1

Transfer Frame	Input Transfer Frame Size (bits)	Input Transfer Frame Rate (Hz)	Destination Interleaver Matrices	Transfer Frames per Interleaver Matrix
$\underline{P1}_G$	9000	$R_b$	$\underline{PU}, \underline{PL}$	8
$\underline{P3}_G$	36000	$R_f$	$\underline{S}, \underline{T}$	1
$\underline{PIDS}_G$	240	$R_b$	$\underline{PIDS}$	1

Table 10-2: Transfer Frame Characteristics – Service Mode MA3

Transfer Frame	Input Transfer Frame Size (bits)	Input Transfer Frame Rate (Hz)	Destination Interleaver Matrices	Transfer Frames per Interleaver Matrix
$\underline{P1}_G$	9000	$R_b$	$\underline{PU}, \underline{PL}$	8
$\underline{P3}_G$	72000	$R_f$	$\underline{S}, \underline{T}$	1
$\underline{PIDS}_G$	240	$R_b$	$\underline{PIDS}$	1

Table 10-3 summarizes the processing of the logical channels in the interleaver. Note that  $T_{T1a}$  is the transmit time alignment delay as described in Subsection 10.1.

Table 10-3: Summary of Logical Channel Processing in the Interleaver

LC	Mode	Subframe	Delay	Interleaver Depth	Interleaver Matrix
P1	MA1, MA3	BL	$T_{dd} + T_{T1a}$	Block	PL
		ML	0	Frame	
		BU	$T_{dd} + T_{T1a}$	Block	PU
		MU	0	Frame	
P3	MA1	EL	0	Frame	T
		EU	0	Frame	S
	MA3	EBL	$T_{dd}$	Frame	T
		EML	0	Frame	
		EBU	$T_{dd}$	Frame	S
		EMU	0	Frame	
PIDS	MA1, MA3	IL	0	Block	PIDS
		IU	0	Block	



## 10.2 Subframe Generation

The first step in the interleaving process is to split the bits of each active input transfer frame into multiple subframes and, at the same time, reorder the bits. The number of subframes for an active logical channel, the division and order of transfer frame bits, and the number of transfer frames needed to fill the subframes, are all dependent upon service mode.

The basic procedure for a given logical channel is as follows:

1. Determine the proper subframe generation structure including bit order for a given logical channel from Figure 10-4 to Figure 10-6, depending on the service mode.
2. Accumulate the indicated number of transfer frames (as shown in the figures below and indicated in Table 10-1 and Table 10-2).
3. For index = 0...N-1, where N represents the total number of input bits (equal to the input transfer frame length times the number of accumulated transfer frames), compute the indicated modulo operation and assign the indexed input bit to the proper subframe in the proper order as shown in the appropriate figure. Subframes are filled sequentially starting with index 0. Notice that the bit indexes change from the read in operation to the sub-frame filling operation.
4. Repeat Steps 1 through 3 for each active logical channel.

Depending on the service mode, some subframes may be delayed before they enter the bit mapping. See, for example, subframes BL and BU in mode MA1 (Figure 10-4).

### 10.3 Interleaver Matrices

A two-dimensional interleaver matrix is used to reorder and group subframe bits. The interleaving process allows individual encoded bits to be directed to specific *interleaver blocks* within the interleaver matrix. An interleaver block can be viewed as a smaller independent interleaver.

In general, an interleaver matrix has 256 rows and an interleaver block has 32 rows. Thus, there are eight interleaver blocks per interleaver matrix. The number of columns in an interleaver matrix depends on the specific matrix. The AM system uses five different interleaver matrices; PU, PL, S, I, and PIDS. Each of the matrices has 25 columns, except the PIDS matrix, which has only two. In addition, the number of bits in each element of a matrix depends not only on the interleaver matrix but also on the service mode. The number of bits per element for each matrix in each service mode is shown in Table 10-4.

Table 10-4: Number of Bits per Interleaver Matrix Element

Service Mode	Interleaver Matrix				
	<u>PU</u>	<u>PL</u>	<u>S</u>	<u>I</u>	<u>PIDS</u>
MA1	6	6	4	2	4
MA3	6	6	6	6	4

#### 10.3.1 PU, PL, S, and I Interleaver Matrices

For the interleaver matrices PU, PL, S, and I, interleaving within each block is performed using the following expression for the row and column indices, where the index k points to one of 750 elements within an interleaver block:

$$\text{Row}(k) = [11 \cdot [(9 \cdot k) \text{ MOD } 25] + 16 \cdot \text{INT}(k/25) + 11 \cdot \text{INT}(k/50)] \text{ MOD } 32$$

$$\text{Column}(k) = (9 \cdot k) \text{ MOD } 25$$

$$\text{for } k = 0, \dots, 749$$

Of the total of 800 (32x25) elements in an interleaver block, the remaining 50 elements are used to transmit a known *training* pattern. The row and column for these training elements are indexed using the same equations above with k being indexed from 750 to 799.

Figure 10-2 shows a 32x25 interleaver block. The number in each element represents the value of k, which produces the row and column index for that element. “T” represents elements containing a training symbol. The bit definition of training symbols for each logical channel in each service mode is given in Table 10-5.

Column (k)

	0	1	2	3	4	5	6	7	8	9	10	11	12	13	14	15	16	17	18	19	20	21	22	23	24
0	0	"T"	728	692	631	595	534	498	437	376	340	279	243	182	146	85	49	"T"	702	666	605	569	508	472	411
1	150	114	53	17	"T"	745	684	648	587	526	490	429	393	332	296	235	199	138	77	41	"T"	719	658	622	561
2	300	264	203	167	106	70	9	"T"	737	676	640	579	543	482	446	385	349	288	227	191	130	94	33	"T"	711
3	450	414	353	317	256	220	159	123	62	1	"T"	729	693	632	596	535	499	438	377	341	280	244	183	147	86
4	600	564	503	467	406	370	309	273	212	151	115	54	18	"T"	746	685	649	588	527	491	430	394	333	297	236
5	"T"	714	653	617	556	520	459	423	362	301	265	204	168	107	71	10	"T"	738	677	641	580	544	483	447	386
6	125	89	28	"T"	706	670	609	573	512	451	415	354	318	257	221	160	124	63	2	"T"	730	694	633	597	536
7	275	239	178	142	81	45	"T"	723	662	601	565	504	468	407	371	310	274	213	152	116	55	19	"T"	747	686
8	425	389	328	292	231	195	134	98	37	"T"	715	654	618	557	521	460	424	363	302	266	205	169	108	72	11
9	575	539	478	442	381	345	284	248	187	126	90	29	"T"	707	671	610	574	513	452	416	355	319	258	222	161
10	725	689	628	592	531	495	434	398	337	276	240	179	143	82	46	"T"	724	663	602	566	505	469	408	372	311
11	50	14	"T"	742	681	645	584	548	487	426	390	329	293	232	196	135	99	38	"T"	716	655	619	558	522	461
12	200	164	103	67	6	"T"	734	698	637	576	540	479	443	382	346	285	249	188	127	91	30	"T"	708	672	611
13	350	314	253	217	156	120	59	23	"T"	726	690	629	593	532	496	435	399	338	277	241	180	144	83	47	"T"
14	500	464	403	367	306	270	209	173	112	51	15	"T"	743	682	646	585	549	488	427	391	330	294	233	197	136
15	650	614	553	517	456	420	359	323	262	201	165	104	68	7	"T"	735	699	638	577	541	480	444	383	347	286
16	25	"T"	703	667	606	570	509	473	412	351	315	254	218	157	121	60	24	"T"	727	691	630	594	533	497	436
17	175	139	78	42	"T"	720	659	623	562	501	465	404	368	307	271	210	174	113	52	16	"T"	744	683	647	586
18	325	289	228	192	131	95	34	"T"	712	651	615	554	518	457	421	360	324	263	202	166	105	69	8	"T"	736
19	475	439	378	342	281	245	184	148	87	26	"T"	704	668	607	571	510	474	413	352	316	255	219	158	122	61
20	625	589	528	492	431	395	334	298	237	176	140	79	43	"T"	721	660	624	563	502	466	405	369	308	272	211
21	"T"	739	678	642	581	545	484	448	387	326	290	229	193	132	96	35	"T"	713	652	616	555	519	458	422	361
22	100	64	3	"T"	731	695	634	598	537	476	440	379	343	282	246	185	149	88	27	"T"	705	669	608	572	511
23	250	214	153	117	56	20	"T"	748	687	626	590	529	493	432	396	335	299	238	177	141	80	44	"T"	722	661
24	400	364	303	267	206	170	109	73	12	"T"	740	679	643	582	546	485	449	388	327	291	230	194	133	97	36
25	550	514	453	417	356	320	259	223	162	101	65	4	"T"	732	696	635	599	538	477	441	380	344	283	247	186
26	700	664	603	567	506	470	409	373	312	251	215	154	118	57	21	"T"	749	688	627	591	530	494	433	397	336
27	75	39	"T"	717	656	620	559	523	462	401	365	304	268	207	171	110	74	13	"T"	741	680	644	583	547	486
28	225	189	128	92	31	"T"	709	673	612	551	515	454	418	357	321	260	224	163	102	66	5	"T"	733	697	636
29	375	339	278	242	181	145	84	48	"T"	701	665	604	568	507	471	410	374	313	252	216	155	119	58	22	"T"
30	525	489	428	392	331	295	234	198	137	76	40	"T"	718	657	621	560	524	463	402	366	305	269	208	172	111
31	675	639	578	542	481	445	384	348	287	226	190	129	93	32	"T"	710	674	613	552	516	455	419	358	322	261

Figure 10-2: Interleaver Row and Column Indices vs k

Table 10-5: Training Bit Patterns

Service Mode	Interleaver Matrix				
	<u>PU</u>	<u>PL</u>	<u>S</u>	<u>I</u>	<u>PIDS</u>
MA1	100101	100101	1001	10	1001
MA3	100101	100101	100101	100101	1001

10.3.2 Interleaver Matrix PIDS

The PIDS interleaver matrix is constructed in the same way regardless of service mode. The interleaving within each interleaver block is performed using the following expressions for the row indices:

$$\text{Row}(k) = [ 11 \cdot (k + \text{INT}(k/15)) + 3 ] \text{ MOD } 32$$

for  $k = 0, \dots, 29$

The index  $k$  points to one of 30 elements within an interleaver block. Of the total of 32 elements in a block, the remaining two elements are used to transmit a known training pattern. The rows for these training elements are indexed using the above equation with  $k$  being indexed from 30 to 31.

In all service modes, the subframes IU and IL are used to fill the PIDS interleaver matrix. IL fills column 0 and IU fills column 1.

From Table 10-4, each element of the PIDS interleaver matrix contains 4 bits. Elements that are reserved for training are filled with the bit pattern shown in Table 10-5. Figure 10-3 shows a 32x1 PIDS interleaver column, illustrating the structure of IU and IL. The number in each element represents the value of  $k$ , which produces the row index for that element. “T” represents elements containing a training symbol.

	0
0	22
1	25
2	28
3	0
4	3
5	6
6	9
7	12
8	"T"
9	17
10	20
11	23
12	26
13	29
14	1
15	4
16	7
17	10
18	13
19	15
20	18
21	21
22	24
23	27
24	"T"
25	2
26	5
27	8
28	11
29	14
30	16
31	19

Figure 10-3: PIDS Interleaver Row Indices vs.  $k$

## 10.4 Bit Mapping

Bit mapping accepts two or more binary subframe vectors and maps each bit in each subframe to a unique location in the destination interleaver matrix. This location includes a row, a column, and a bit position within the element determined by the row and column. This reordering of bits before transmission mitigates the impact of burst errors caused by signal fades and interference.

Figure 10-4 through Figure 10-6 show how to generate the block number  $b$  that determines the interleaver block within an interleaver matrix, the index  $k$  that determines the row and column in an interleaver block, and the index  $p$  that determines the bit position within the interleaver block element for each logical channel in each service mode. The bit mapping process is as follows:

1. For a given subframe vector in a given service mode, select the proper bit mapping equations from Figure 10-4 through Figure 10-6.
2. For  $n = 0 \dots L-1$ , where  $L$  represents the subframe vector length, compute the parameters  $b$ ,  $k$ , and  $p$ .
3. Compute the row and column indices for the destination interleaver matrix using the equations in Subsection 10.3.2 (for PIDS) or Subsection 10.3.1 (for all other matrices).
4. Transfer the subframe bit of index  $n$  to the destination interleaver matrix position at the computed row, column, block, and position indices.
5. Repeat steps (1) through (4) for all logical channels destined for a particular interleaver matrix.
6. Populate the interleaver matrix with the proper training symbols defined in Table 10-5.

## 10.5 Transfer Frame Time Alignment

Interleaving must maintain a specific transfer frame alignment and synchronization at its output. For a given logical channel, the BC range  $m1:m2$  indicates which  $L1$  blocks are spanned by the designated transfer frame. The ALFN  $n$  is the absolute  $L1$  frame number.

## 10.6 Service Mode MA1

In service mode MA1, the PU, PL, S, T, interleaver matrices are populated as shown in Figure 10-4 and the PIDS interleaver matrix is populated as shown in Figure 10-5.

The PL interleaver matrix is populated with subframes BL and ML. The top set of equations from Figure 10-4 are used to determine the block index  $b$ , the index  $k$  and the bit position  $p$  for the BL subframe. Similarly, the second set of equations from the top is used for the ML subframe. The subframe index  $n$  ranges from 0 to 17,999 for both subframes. Before populating PL, subframe BL is delayed by  $T_{dd} + T_{T1a}$ . From Table 10-4, each element of the PL interleaver matrix contains 6 bits. Row and column indices are computed from the equations in Subsection 10.3.1. Elements that are reserved for training are filled with the bit pattern 100101 obtained from Table 10-5.

The other interleaver matrices are populated in a similar fashion as shown in Figure 10-4 and Figure 10-5.

### 10.7 Service Mode MA3

In service mode MA3, the PU, PL, S, T, and PIDS interleaver matrices are populated for input to the OFDM subcarrier mapping. Refer to Figure 10-6 and Figure 10-5 for details.

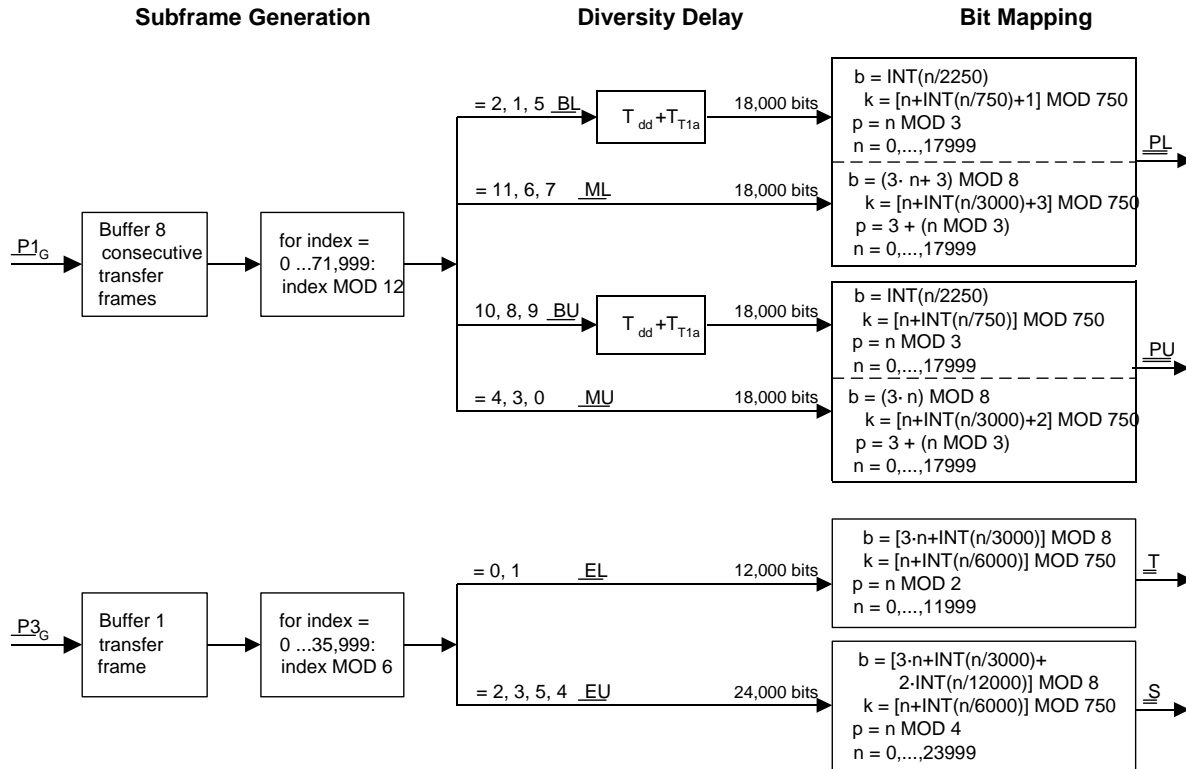

Figure 10-4: Interleaving – Service Mode MA1

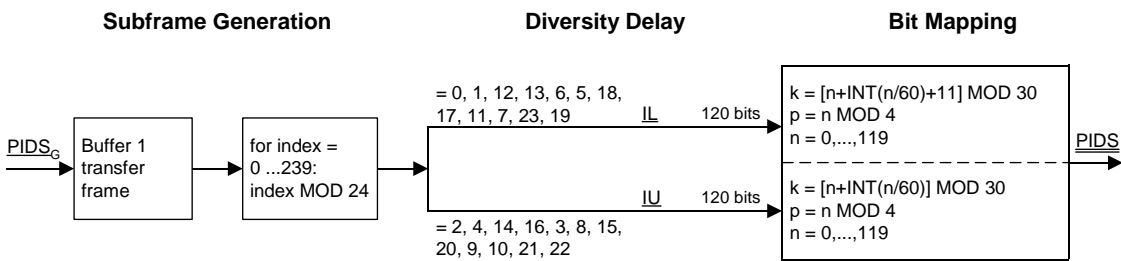

Figure 10-5: PIDS Interleaving Process – All Service Modes

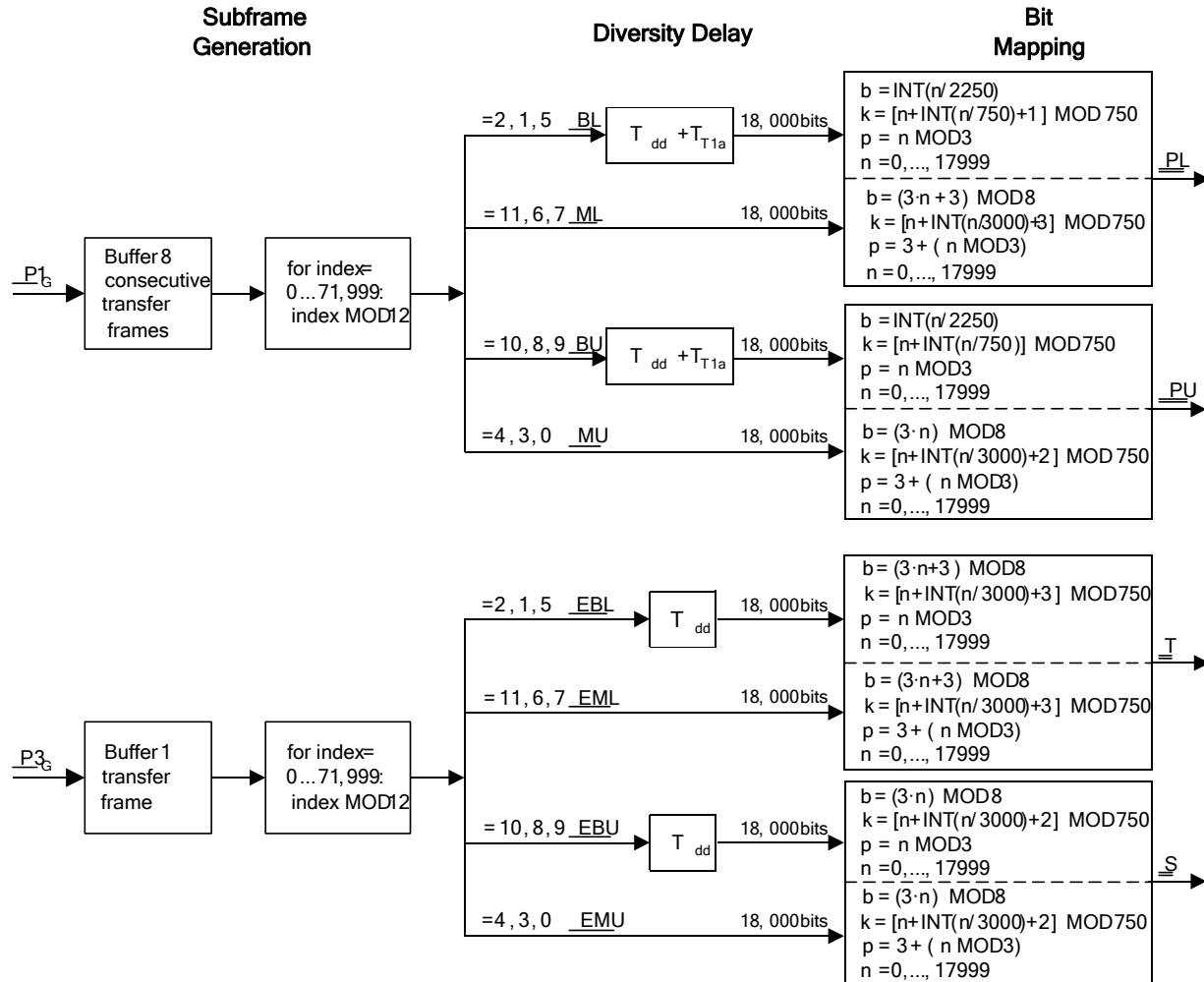

Figure 10-6: Interleaving – Service Mode MA3

## 11 System Control Processing

### 11.1 Introduction

System control processing receives system control data from the Configuration Administrator via the SCCH. This data is combined with synchronization, *parity*, and reserved bits within Layer 1 to create system control data sequences. The resulting sequences are destined for the reference subcarriers located on both sides of the main analog carrier.

The resulting output is a column vector  $\underline{R}$  of fixed dimension. The number of elements of  $\underline{R}$  corresponds to the number of OFDM symbols per L1 frame. The vector  $\underline{R}$  is comprised of eight 32-bit sequences, one for each L1 block, and is output at the L1 frame rate,  $R_f$ . In addition, system control processing provides, via the SCCH, the L1 block count to Layer 2 at the L1 block rate,  $R_b$ . A conceptual view of the system control processing is shown in Figure 11-1.

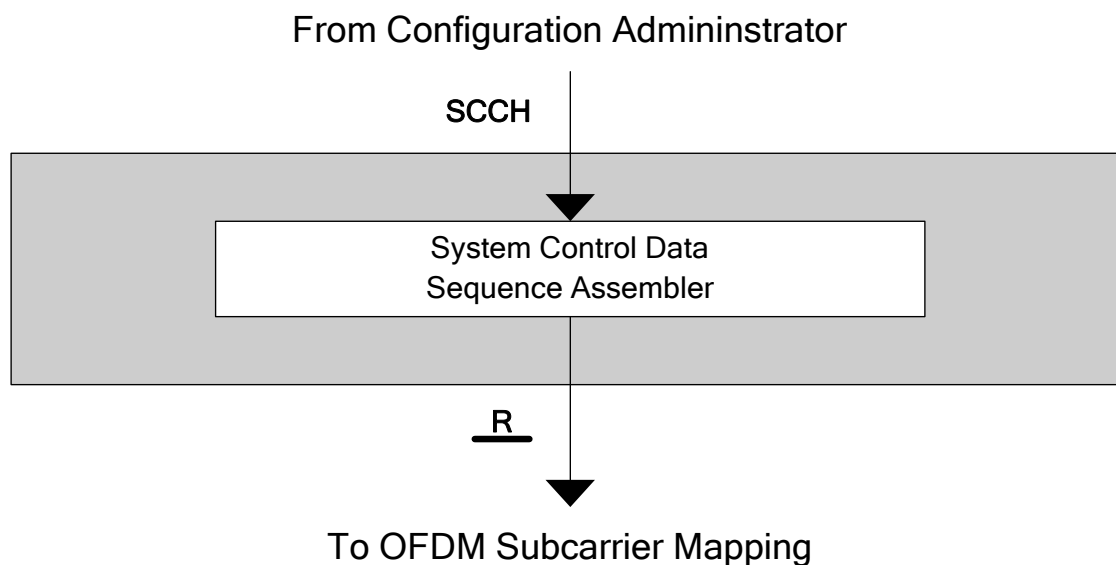

Figure 11-1: System Control Processing Conceptual Diagram

### 11.2 System Control Data Sequence Assembler

The system control data sequence assembler collects information from the Configuration Administrator and creates a vector of eight 32-bit system control data sequences. Each element of the vector contains one bit. Each of the eight data sequences is comprised of bit fields that represent various system control components as well as synchronization and timing information. The system control data sequence is depicted in Figure 11-2 and defined in Table 11-1.

The subsections that follow this section describe each of the bit fields. Bits 31 to 0 of the system control data sequence, map to bits 0 to 31, 32 to 63, 64 to 95, 96 to 127, 128 to 159, 160 to 191, 192 to 223, and 224 to 255 of  $\underline{R}$ , respectively. Refer to Subsection 12.2.3 for a discussion of how  $\underline{R}$  is mapped to the reference subcarriers.



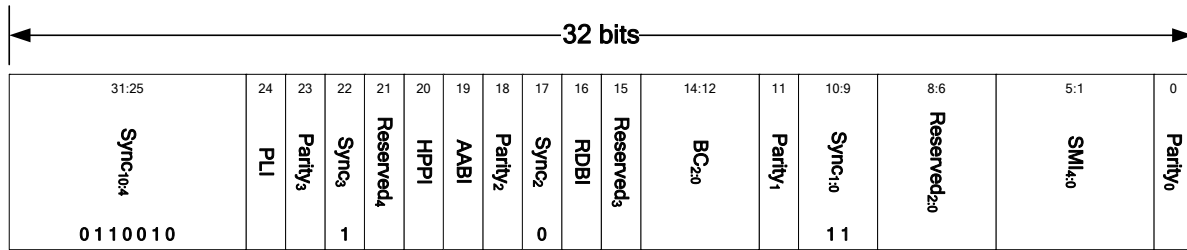

Figure 11-2: System Control Data Sequence

Table 11-1: System Control Data Sequence Bit Allocations

Field	Bit Location	Bit Length	Description
Sync <sub>10:4</sub>	31:25	7	Sync <sub>10:4</sub> = 0110010
Power Level Indicator (PLI)	24	1	0 = Hybrid carriers scaled by CH <sub>S1</sub> , CH <sub>I1</sub> , and CH <sub>T1</sub> 1 = Hybrid carriers scaled by CH <sub>S2</sub> , CH <sub>I2</sub> , and CH <sub>T2</sub>
Parity <sub>3</sub>	23	1	Even Parity for PLI
Sync <sub>3</sub>	22	1	Sync <sub>3</sub> = 1
Reserved <sub>4</sub>	21	1	For future expansion
HPPI	20	1	High-Power PIDS Indicator
Analog Audio Bandwidth Indicator (AABI)	19	1	0 = 5 kHz analog audio bandwidth 1 = 8 kHz analog audio bandwidth
Parity <sub>2</sub>	18	1	Even Parity for Reserved <sub>4</sub> , HPPI, and AABI
Sync <sub>2</sub>	17	1	Sync <sub>2</sub> = 0
RDBI	16	1	Reduced Digital Bandwidth Indicator
Reserved <sub>3</sub>	15	1	For future expansion
Block Count (BC <sub>2:0</sub> )	14:12	3	Modulo-8 count which increments every 32 OFDM symbols
Parity <sub>1</sub>	11	1	Even Parity for RDBI, Reserved <sub>3</sub> and Block Count
Sync <sub>1:0</sub>	10:9	2	Sync <sub>1:0</sub> = 11
Reserved <sub>2:0</sub>	8:6	3	For future expansion
Service Mode Indicator (SMI <sub>4:0</sub> )	5:1	5	Identifies service mode currently selected
Parity <sub>0</sub>	0	1	Even parity for Reserved <sub>2:0</sub> and SMI

### 11.2.1 Block Synchronization (Sync)

The block synchronization (sync) bits serve to aid in receiver synchronization. The sync bit pattern is distributed over the system control data sequence as shown in Table 11-1 and Figure 11-2.

### 11.2.2 Power Level Indicator (PLI)

The power level indicator (PLI) is a one-bit flag used to indicate the nominal level of the secondary and tertiary sidebands when transmitting a Hybrid waveform. If the flag is cleared, the subcarriers in the secondary, PIDS, and tertiary sideband have been scaled by  $CH_{S1}$ ,  $CH_{T1}$ , and  $\underline{CH}_{T1}$ ; if the flag is set, these subcarriers have been scaled by  $CH_{S2}$ ,  $CH_{T2}$ , and  $\underline{CH}_{T2}$ . See Reference [9] for detailed information concerning the levels of the sidebands. The PLI flag is always 0 when an All Digital waveform is being transmitted.

When RDBI is set to 1, PLI is not applicable and shall always be zero. Otherwise, PLI reflects the current configuration as controlled by the PL control signal received from the configuration administrator. Refer to Subsection 6.3 for specific details on how PL affects the spectral profile.

### 11.2.3 High-Power PIDS Indicator (HPPI)

The High Power PIDS Indicator (HPPI) is a one-bit flag used to indicate the level of the PIDS2/PIDS2\* subcarriers in service mode MA1 and the PIDS1/PIDS2 subcarriers in service mode MA3. If HPPI is 0, these PIDS subcarriers are in the standard low-power configuration. If HPPI is 1, these PIDS subcarriers are in the high-power configuration.

When RDBI is set to 1, HPPI is not applicable and shall always be 0. Otherwise, HPPI reflects the current configuration as controlled by the HPP control signal received from the configuration administrator. Refer to Subsection 6.3 for specific details on how HPP affects the spectral profile.

### 11.2.4 Analog Audio Bandwidth Indicator (AABI)

The analog audio bandwidth indicator (AABI) is a one-bit flag used to indicate the maximum bandwidth of the analog audio signal when transmitting a Hybrid waveform. If the flag is cleared, the maximum analog audio bandwidth is 5 kHz; if the flag is set, the maximum analog audio bandwidth is 8 kHz. The AABI flag is always 0 when an All Digital waveform is being transmitted.

### 11.2.5 Reduced Digital Bandwidth Indicator (RDBI)

The Reduced Digital Bandwidth Indicator (RDBI) is a one-bit flag to indicate the spectral profile of the MA1 and MA3 waveform. When RDBI is 0 (standard configuration), the secondary and tertiary sidebands are enabled, and the PIDS subcarriers are all active.

When RDBI is 1 (reduced bandwidth configuration), the secondary and tertiary sidebands are disabled. In addition, for service mode MA1, the PIDS1 and PIDS1\* subcarriers are disabled. In both service modes MA1 and MA3, when RDBI is 1, the active PIDs subcarriers are in the high-power configuration.

When RDBI is set to 1, the state of the PLI and HPPI indicators shall be zero.

RDBI reflects the current configuration as controlled by the RDB control signal received from the configuration administrator. Refer to Subsection 6.3 for specific details on how RDB affects the spectral profile.

### 11.2.6 L1 Block Count (BC)

The L1 Block Count (BC<sub>2:0</sub>) is a modulo-8 counter indicating the current L1 block within an L1 frame. The L1 Block Count increments on each 32-OFDM-symbol boundary. An L1 Block Count of 0 signifies the start of an L1 frame, while an L1 Block Count of 7 signifies the final block of an L1 frame. The first L1 Block Count inserted into the system control data sequence is 0. The L1 Block Count bit assignments are shown in Table 11-2.

Table 11-2: L1 Block Count Bit Assignments

L1 Block Count	BC <sub>2:0</sub> Bit Assignment (Bits 14:12)
0	000
1	001
2	010
3	011
4	100
5	101
6	110
7	111

### 11.2.7 Service Mode Indicator (SMI)

The AM HD Radio system supports one Hybrid service mode (MA1) and one All Digital service mode (MA3), as defined in Section 6. The service mode indicator (SMI<sub>4:0</sub>) is a five-bit field that uniquely indicates the current service mode. The definition of SMI<sub>4:0</sub> for each service mode is shown in Table 11-3. Values 00011 through 11111 are reserved.

Table 11-3: AM HD Radio Service Mode Bit Assignments

Service Mode	Service Mode Indicator (Bits 4:0)
None	00000
MA1	00001
MA3	00010
Reserved	00011 - 11111

Each of the reserved service modes must maintain backward compatibility as defined in Subsection 6.2.1. Thus first generation receivers will always configure themselves to one of the basic operational modes MA1 or MA3 when one of the reserved modes is detected. The one exception to this is when the two least significant bits of PSMI are both zero. In this case, backward compatibility is not maintained. This case is reserved for system test modes and operational receivers will assume that the service mode is “None” and all outputs will be disabled.

## 12 OFDM Subcarrier Mapping

### 12.1 Introduction

OFDM subcarrier mapping transforms rows of interleaver matrices into scaled *QPSK*, 16-QAM or 64-QAM symbols in service modes MA1 and MA3 and maps them to specific OFDM subcarriers in the output vector  $\underline{X}$ . System control data sequence bits from  $\underline{R}$  are transformed into *BPSK* symbols and mapped to the two reference subcarrier locations in  $\underline{X}$ . Figure 12-1 shows the inputs, output, and component functions of OFDM subcarrier mapping.

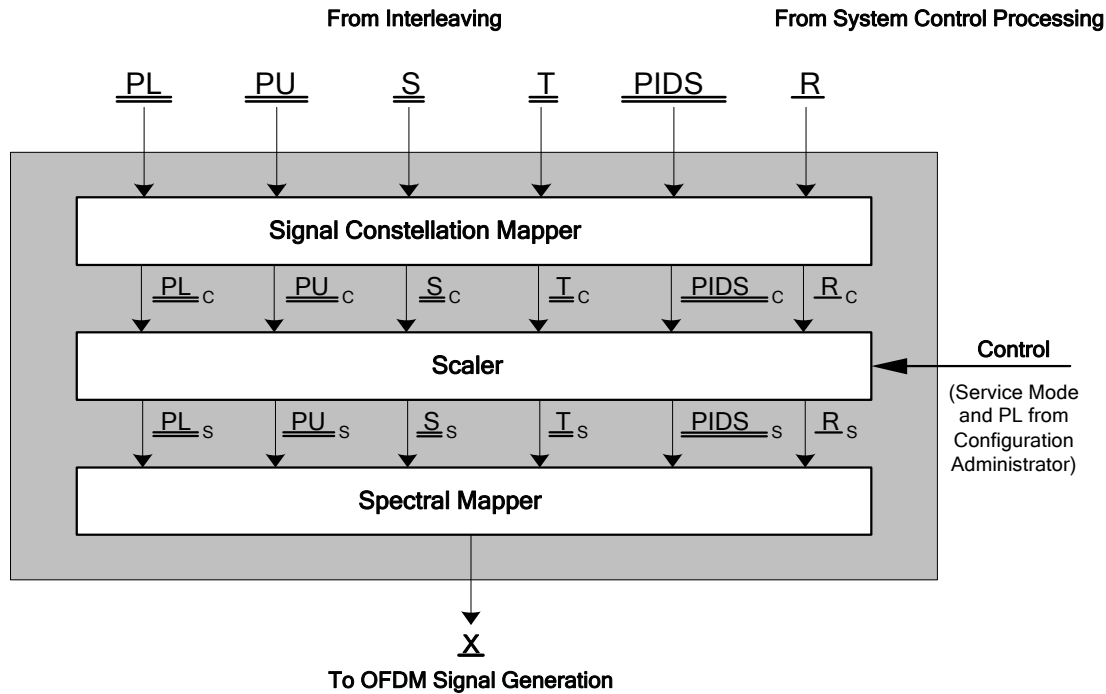

Figure 12-1: OFDM Subcarrier Mapping Functional Block Diagram

The inputs to OFDM subcarrier mapping are the interleaver matrices  $\underline{PL}$ ,  $\underline{PU}$ ,  $\underline{S}$ ,  $\underline{T}$ ,  $\underline{PIDS}$ , and  $\underline{R}$ , the system control data sequence vector. Matrices  $\underline{S}$ ,  $\underline{T}$ ,  $\underline{PIDS}$ , and  $\underline{R}$  are mapped to the secondary, tertiary, IDS, and reference subcarriers respectively. Matrices  $\underline{PL}$  and  $\underline{PU}$  are mapped to the primary lower and primary upper subcarriers, respectively.

The output from OFDM subcarrier mapping for each OFDM symbol is a single complex vector,  $\underline{X}$ , of length 163. The vector is indexed by  $k = 0, 1, 2, \dots, 162$ . The  $k^{\text{th}}$  element of  $\underline{X}$  corresponds to subcarrier  $(k - 81)$ , as shown in Figure 12-2.

Index into $\underline{X}$	0	1	2	...	160	161	162
Subcarrier Number	-81	-80	-79	...	79	80	81

Figure 12-2: Assignment of Output Vector  $\underline{X}$  Elements to Subcarriers

The elements of  $\underline{X}$  are populated based on service mode. Elements corresponding to unused subcarriers are set to the complex value  $0 + j0$ . Elements of  $\underline{R}$  and the associated row from each active interleaver matrix are assigned to the same instance of  $\underline{X}$ .

The first block in Figure 12-1 is the *signal constellation mapper*, which converts the individual elements of the various interleaver matrices from digital words to complex values representing constellation points. The dimensions of the interleaver matrices, therefore, remain unchanged during this process. However, to distinguish between the interleaver matrices before and after their elements have been transformed to constellation values, a subscript “C” is added after the mapping has been performed.

The next block in Figure 12-1 is the scaler. This block multiplies each complex element of the interleaver matrices by a scale factor to place the subcarriers at the appropriate level relative to the unmodulated carrier. To indicate that scaling has been applied, a subscript “S” is added to the interleaver matrices.

The final block in Figure 12-1 is the spectral mapper. This block places the scaled constellation values in the appropriate position in the output vector  $\underline{X}$ .

## 12.2 OFDM Subcarrier Mapping Procedures

The details of how the elements of each interleaver matrix get mapped to complex constellation values is described in Subsections 12.2.1, 12.2.2, and 12.2.3, beginning with the primary interleaver matrices.

For each active interleaver matrix, a row is processed every  $T_s$  seconds. Rows are processed sequentially, starting with the first row (Row 0). When all rows of an interleaver matrix have been processed, the next instance of that interleaver matrix is processed, starting with the first row. The columns of an interleaver matrix map directly to OFDM subcarriers. Subcarriers -56, -55, -54, 0, 54, 55, and 56 are never used and therefore are always set to  $(0 + j0)$ .

### 12.2.1 Primary Subcarriers

The 256x25 primary interleaver matrices ( $\underline{PU}$  and  $\underline{PL}$ ) are mapped to 64-QAM constellations. The elements of these matrices are six-bit words. To map each six-bit word within an interleaver matrix to a subcarrier location within the vector  $\underline{X}$ , the following steps are taken:

1. Read a six-bit word from an element within an interleaver matrix.
2. Map the six-bit word from Step 1 to a complex constellation value using Table 12-1.
3. Scale the I and Q components of the complex constellation value from Step 2 using the appropriate amplitude scale factor from Table 12-11.
4. Map the scaled constellation value from Step 3 to the appropriate element of  $\underline{X}$  using Table 12-2 or Table 12-3.

There is a one-to-one mapping from primary interleaver matrix columns to OFDM subcarriers. In both the Hybrid and All Digital waveforms,  $\underline{PU}_S$  and  $\underline{PL}_S$  map to the primary sidebands as shown in Table 12-2 and Table 12-3. In each case, the mapping begins with the subcarrier index with the lowest absolute value and continues to the subcarrier index with the highest absolute value. In the Hybrid waveform, the first element of  $\underline{PU}_S$  maps to subcarrier 57 and the first element of  $\underline{PL}_S$  maps to subcarrier -57. In the All Digital waveform, the first element of  $\underline{PU}_S$  maps to subcarrier 2 and the first element of  $\underline{PL}_S$  maps to subcarrier -2. In addition, the constellation values of the lower sidebands are negated and complex conjugated. This is indicated in Table 12-2 and Table 12-3 by a minus sign and an asterisk appended to the interleaver matrix designation, for example,  $-\underline{PL}_S^*$ .

Table 12-1: 64-QAM Constellation Mapping

6 bit word $X_5X_4X_3X_2X_1X_0$	Hex	Constellation Value	6 bit word $X_5X_4X_3X_2X_1X_0$	Hex	Constellation Value
000000	0	-3.5 - j3.5	100000	20	-3.5 - j2.5

6 bit word X <sub>5</sub> X <sub>4</sub> X <sub>3</sub> X <sub>2</sub> X <sub>1</sub> X <sub>0</sub>	Hex	Constellation Value	6 bit word X <sub>5</sub> X <sub>4</sub> X <sub>3</sub> X <sub>2</sub> X <sub>1</sub> X <sub>0</sub>	Hex	Constellation Value
000001	1	3.5 - j3.5	100001	21	3.5 - j2.5
000010	2	-0.5 - j3.5	100010	22	-0.5 - j2.5
000011	3	0.5 - j3.5	100011	23	0.5 - j2.5
000100	4	-2.5 - j3.5	100100	24	-2.5 - j2.5
000101	5	2.5 - j3.5	100101	25	2.5 - j2.5
000110	6	-1.5 - j3.5	100110	26	-1.5 - j2.5
000111	7	1.5 - j3.5	100111	27	1.5 - j2.5
001000	8	-3.5 + j3.5	101000	28	-3.5 + j2.5
001001	9	3.5 + j3.5	101001	29	3.5 + j2.5
001010	A	-0.5 + j3.5	101010	2A	-0.5 + j2.5
001011	B	0.5 + j3.5	101011	2B	0.5 + j2.5
001100	C	-2.5 + j3.5	101100	2C	-2.5 + j2.5
001101	D	2.5 + j3.5	101101	2D	2.5 + j2.5
001110	E	-1.5 + j3.5	101110	2E	-1.5 + j2.5
001111	F	1.5 + j3.5	101111	2F	1.5 + j2.5
010000	10	-3.5 - j0.5	110000	30	-3.5 - j1.5
010001	11	3.5 - j0.5	110001	31	3.5 - j1.5
010010	12	-0.5 - j0.5	110010	32	-0.5 - j1.5
010011	13	0.5 - j0.5	110011	33	0.5 - j1.5
010100	14	-2.5 - j0.5	110100	34	-2.5 - j1.5
010101	15	2.5 - j0.5	110101	35	2.5 - j1.5
010110	16	-1.5 - j0.5	110110	36	-1.5 - j1.5
010111	17	1.5 - j0.5	110111	37	1.5 - j1.5
011000	18	-3.5 + j0.5	111000	38	-3.5 + j1.5
011001	19	3.5 + j0.5	111001	39	3.5 + j1.5
011010	1A	-0.5 + j0.5	111010	3A	-0.5 + j1.5
011011	1B	0.5 + j0.5	111011	3B	0.5 + j1.5
011100	1C	-2.5 + j0.5	111100	3C	-2.5 + j1.5
011101	1D	2.5 + j0.5	111101	3D	2.5 + j1.5
011110	1E	-1.5 + j0.5	111110	3E	-1.5 + j1.5
011111	1F	1.5 + j0.5	111111	3F	1.5 + j1.5

Table 12-2: Primary Interleaver Subcarrier Mapping – Hybrid Waveform

Mode	Starting Subcarrier Number	Ending Subcarrier Number	Interleaver Matrix	Interleaver Matrix Starting Column Number	Interleaver Matrix Ending Column Number
MA1	-57	-81	$-\underline{PL}_S^*$	0	24
MA1	57	81	$\underline{PU}_S$	0	24

Table 12-3: Primary Interleaver Subcarrier Mapping – All Digital Waveform

Mode	Starting Subcarrier Number	Ending Subcarrier Number	Interleaver Matrix	Interleaver Matrix Starting Column Number	Interleaver Matrix Ending Column Number
MA3	-2	-26	$-\underline{PL}_S^*$	0	24
MA3	2	26	$\underline{PU}_S$	0	24

### 12.2.2 Secondary and Tertiary Subcarriers

In both the Hybrid and All Digital waveforms,  $\underline{S}$  maps to the secondary sideband and  $\underline{T}$  maps to the tertiary sideband. However, in the Hybrid waveform there is not a one-to-one mapping and different modulation types are employed. For these reasons the Hybrid and All Digital waveforms are treated in separate subsections.

#### 12.2.2.1 Hybrid Waveform

The secondary and  $\underline{PIDS}$  interleaver matrices are mapped to 16-QAM constellations while the tertiary interleaver matrix is mapped to QPSK constellations.  $\underline{S}$  and  $\underline{T}$  have dimensions of 256x25 and each element of  $\underline{S}$  contains a four-bit word while the elements of  $\underline{T}$  contain two-bit words. The  $\underline{PIDS}_S$  matrix has dimensions of 32x2 and consists of four-bit words.

To map each four-bit, or two-bit, word within an interleaver matrix to a subcarrier location within the vector  $\underline{X}$ , the following steps are taken:

1. Read a four-bit, or two-bit, word from a column within an interleaver matrix.
2. Map the four-bit, or two-bit, word from Step 1 to a complex constellation value using Table 12-4 for two-bit words and Table 12-5 for four-bit words.
3. Scale the I and Q components of the complex constellation value from Step 2 using the appropriate amplitude scale factor from Table 12-11. Where more than one scale factor is indicated, selection is determined by PL, input from the Configuration Administrator via the SCCH.
4. Map the scaled constellation value from Step 3 to the appropriate element of  $\underline{X}$  using Table 12-6 or Table 12-7.

The procedure for mapping the constellation values in the elements of  $\underline{S}_S$  and  $\underline{T}_S$  to the secondary and tertiary sidebands for the Hybrid waveform is as follows. First, map the elements of  $\underline{S}_S$  onto the secondary upper sideband starting with the lowest subcarrier index and continuing until all columns of  $\underline{S}_S$  in the row of interest are mapped. Next, map the negated complex conjugated elements of  $\underline{S}_S$  onto the lower secondary sideband starting with the subcarrier index with the lowest absolute value and continuing until all columns of  $\underline{S}_S$  in the row of interest are mapped. Repeat this procedure for  $\underline{T}_S$ , and the tertiary sidebands.

The  $\underline{\text{PIDS}}_s$  matrix also maps to the secondary sidebands. The first interleaver column (0) of  $\underline{\text{PIDS}}_s$  maps to the carriers  $\pm 27$  and the second column maps to carriers  $\pm 53$ . Each column maps to two carriers. Therefore, the constellations on the negative carriers are first negated and complex conjugated as shown in Table 12-7.

Table 12-4: QPSK Constellation Mapping

2 bit word $x_1x_0$	Hex	Constellation Value
00	0	$-0.5 - j0.5$
01	1	$0.5 - j0.5$
10	2	$-0.5 + j0.5$
11	3	$0.5 + j0.5$

Table 12-5: 16-QAM Constellation Mapping

4 bit word $x_3x_2x_1x_0$	Hex	Constellation Value
0000	0	$-1.5 - j1.5$
0001	1	$1.5 - j1.5$
0010	2	$-0.5 - j1.5$
0011	3	$0.5 - j1.5$
0100	4	$-1.5 + j1.5$
0101	5	$1.5 + j1.5$
0110	6	$-0.5 + j1.5$
0111	7	$0.5 + j1.5$
1000	8	$-1.5 - j0.5$
1001	9	$1.5 - j0.5$
1010	A	$-0.5 - j0.5$
1011	B	$0.5 - j0.5$
1100	C	$-1.5 + j0.5$
1101	D	$1.5 + j0.5$
1110	E	$-0.5 + j0.5$
1111	F	$0.5 + j0.5$



Table 12-6: Secondary and Tertiary Interleaver Subcarrier Mapping – Hybrid Waveform

Starting Subcarrier Number	Ending Subcarrier Number	Interleaver Matrix	Interleaver Matrix Starting Column Number	Interleaver Matrix Ending Column Number
2	26	$\underline{T}_S$	0	24
28	52	$\underline{S}_S$	0	24
-2	-26	$-\underline{T}_S^*$	0	24
-28	-52	$-\underline{S}_S^*$	0	24

Table 12-7: PIDS Interleaver Subcarrier Mapping – Hybrid Waveform

Subcarrier Number	Interleaver Matrix	Interleaver Matrix Column Number
-27	$-\underline{PIDS}_S^*$	0
-53	$-\underline{PIDS}_S^*$	1
27	$\underline{PIDS}_S$	0
53	$\underline{PIDS}_S$	1

### 12.2.2.2 All Digital Waveform

In the All Digital waveform, the secondary and tertiary interleaver matrices are mapped to 64-QAM constellations while the PIDS interleaver matrix is mapped to 16-QAM constellations.  $\underline{S}$  and  $\underline{T}$  have dimensions of 256x25 and each element contains a six-bit word. The PIDS matrix has elements consisting of four-bit words and has dimensions 32x2.

To map each six/four-bit word within an interleaver matrix to a subcarrier location within the vector X, the following steps are taken:

1. Read a six/four-bit word from a column within an interleaver matrix.
2. Map the six/four-bit word from Step 1 to a complex constellation value using Table 12-1 for six-bit words and Table 12-5 for four-bit words.
3. Scale the I and Q components of the complex constellation value from Step 2 using the appropriate amplitude scale factor from Table 12-11.
4. Map the scaled constellation values from Step 3 to the appropriate element of X using Table 12-8 or Table 12-9.

There is a one-to-one mapping from secondary, tertiary, and PIDS interleaver matrix columns to OFDM subcarriers. The secondary interleaver maps to the secondary sideband, the tertiary interleaver matrix maps to the tertiary sideband, and the PIDS interleaver matrix maps to both secondary and tertiary sidebands. For the PIDS interleaver matrix, the first column maps to the index with the lowest absolute value in the tertiary (-27) sideband and the second column maps to the subcarrier index with the lowest absolute value in the secondary (+27) as indicated in Table 12-9. The mapping for both  $\underline{S}_S$  and  $\underline{T}_S$  begins with the subcarrier index with the second lowest absolute value and continues to the subcarrier with the highest absolute value. As with the primary lower interleaver matrix, the constellation of  $\underline{T}_S$  is negated and complex conjugated. Similarly the column of the PIDS matrix that gets mapped to -27 is also negated and complex conjugated. The mapping of  $\underline{S}_S$  and  $\underline{T}_S$  for the All Digital waveform is summarized in Table 12-8.

Table 12-8: Secondary and Tertiary Interleaver Subcarrier Mapping – All Digital Waveform

Starting Subcarrier Number	Ending Subcarrier Number	Interleaver Matrix	Interleaver Matrix Starting Column Number	Interleaver Matrix Ending Column Number
-28	-52	$-\underline{T}_S^*$	0	24
28	52	$\underline{S}_S$	0	24

Table 12-9: PIDS Interleaver Subcarrier Mapping – All Digital Waveform

Subcarrier Number	Interleaver Matrix	Interleaver Matrix Column Number
-27	$-\underline{PIDS}_S^*$	0
27	$\underline{PIDS}_S$	1

### 12.2.3 Reference Subcarriers

The input vector  $\underline{R}$  consists of 256 bits (that is, a single bit for every OFDM symbol in an L1 frame). The bits of this vector are mapped to BPSK constellation points as shown in Table 12-10.

To map each bit within the  $\underline{R}$  vector to a subcarrier location within the vector  $\underline{X}$ , the following steps are taken:

1. Read a bit from the vector  $\underline{R}$ .
2. Map the bit from Step 1 to a complex constellation value using Table 12-10.
3. Scale the I and Q components of the complex constellation value from Step 2 using the appropriate amplitude scale factor from Table 12-11.
4. Map the scaled constellation value from Step 3 to the appropriate elements of  $\underline{X}$  using
5. Table 12-12.

Table 12-10: BPSK Signal Constellation Mapping

$n^{\text{th}}$ Bit Value	$n^{\text{th}}$ Constellation Point
0	$0 - j0.5$
1	$0 + j0.5$

Table 12-11: Signal Constellation Scale Factors

Interleaver Matrix	Waveform	
	Hybrid	All Digital
$\underline{PUC}$	$CH_P$	$CD_P$
$\underline{PLC}$	$CH_P$	$CD_P$
$\underline{SC}$	$CH_{S1}$ or $CH_{S2}$	$CD_E$
$\underline{TC}$	$\underline{CH}_{T1}[25]$ or $\underline{CH}_{T2}[25]$	$CD_E$

Interleaver Matrix	Waveform	
	Hybrid	All Digital
$\underline{PIDS}_C$	CH <sub>1</sub> or CH <sub>2</sub>	CD <sub>1</sub>
$\underline{R}_C$	CH <sub>B</sub>	CD <sub>B</sub>

Table 12-12: R Subcarrier Mapping – Hybrid and All Digital Waveforms

Subcarrier Number	System Control Data Sequence Vector	Interleaver Vector Column Number
-1	$-\underline{R}_S^*$	0
1	$\underline{R}_S$	0

## 13 OFDM Signal Generation

### 13.1 Introduction

OFDM signal generation receives complex frequency-domain OFDM symbols from the output of OFDM subcarrier mapping and outputs time-domain pulses representing the digital portion of the AM HD Radio signal. A conceptual block diagram of OFDM signal generation is shown in Figure 13-1.

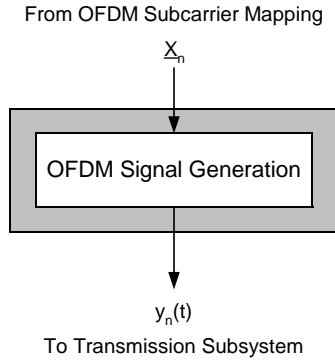

Figure 13-1: OFDM Signal Generation Conceptual Block Diagram

The input to OFDM signal generation is a complex vector,  $\underline{X}_n$  of length  $L$ , representing the complex constellation values for each OFDM subcarrier in OFDM symbol  $n$ . For notational convenience, the output of OFDM Subcarrier Mapping described in Section 12 did not use the subscript  $n$ . Rather it represented the vector  $\underline{X}$  as a single OFDM symbol. In this section, the subscript is appended to  $\underline{X}$  because of the significance of  $n$  to OFDM signal generation.

The output of OFDM signal generation is a complex, baseband, time-domain pulse  $y_n(t)$ , representing the digital portion of the AM HD Radio signal for symbol  $n$ .

### 13.2 Functionality

Let  $\underline{X}_n[k]$  be the complex scaled constellation points from OFDM subcarrier mapping for the  $n^{\text{th}}$  symbol, where  $k = 0, 1, \dots, L-1$  indexes the OFDM subcarriers. Let  $y_n(t)$  denote the complex time-domain output of OFDM signal generation for the  $n^{\text{th}}$  symbol. Then  $y_n(t)$  can be written in terms of  $\underline{X}_n[k]$  as follows:

$$y_n(t) = W(t - nT_s) \cdot \sum_{k=0}^{L-1} \underline{X}_n[k] \cdot e^{j2\pi\Delta f \left[ k - \frac{L-1}{2} \right] \cdot (t - nT_s)}$$

where  $n = 0, 1, \dots, \infty$ ,  $0 \leq t \leq \infty$ ,  $L = 163$  is the maximum number of OFDM subcarriers, and  $T_s$  and  $\Delta f$  are the OFDM symbol period and OFDM subcarrier spacing, respectively, as defined in Subsection 3.5.

The *pulse-shaping function*  $W(\xi)$  is defined as:

$$W(\xi) = \begin{cases} 0 & \text{for } \xi < 0 \\ \sqrt{\frac{1}{3\sqrt{2\pi}}} \int_{-\infty}^{\infty} e^{-4050\left(\frac{\tau}{T_s}\right)^2} H(\xi - \tau) d\tau & \text{for } 0 \leq \xi \leq \frac{348}{270} T_s \\ 0 & \text{for } \xi > \frac{348}{270} T_s \end{cases}$$

where

$$H(\xi) = \begin{cases} 0.5 \cdot \left[ 1 + \cos\left(\pi \frac{\alpha T - \xi}{\alpha T}\right) \right], & \text{for } 0 < \xi \leq \alpha T \\ 1.0, & \text{for } \alpha T < \xi < T \\ 0.5 \cdot \left[ 1 + \cos\left(\pi \frac{\xi - T}{\alpha T}\right) \right], & \text{for } T \leq \xi \leq (1 + \alpha)T \\ 0, & \text{otherwise} \end{cases}$$

$\alpha$  is the cyclic prefix width defined in Subsection 3.5, and  $T = 1/\Delta f$  is the reciprocal of the OFDM subcarrier spacing. Figure 13-2 shows a plot of the pulse shaping function  $W(\xi)$ .

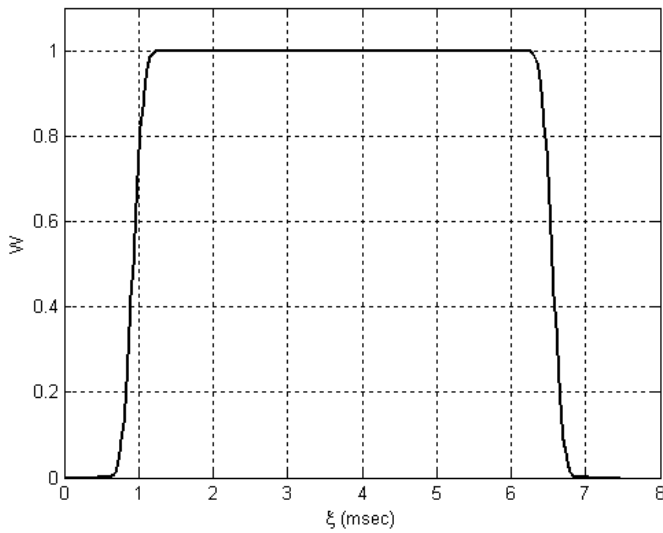

Figure 13-2: Pulse Shaping Function

# 14 Transmission Subsystem

## 14.1 Introduction

The transmission subsystem formats the baseband AM HD Radio waveform for transmission through the MF channel. Functions include symbol concatenation and frequency up-conversion. In addition, when transmitting the Hybrid waveform, this function filters and modulates the baseband analog audio signal before coherently combining it with the digital portion of the waveform.

The input to this module is a complex, baseband, time-domain OFDM symbol,  $y_n(t)$ , from OFDM signal generation. A baseband analog audio signal,  $m(t)$ , after application of analog diversity delay  $T_{ad}$  plus an appropriate implementation-specific *Transmit Audio Alignment Delay*,  $T_{T5a}$ , is also input from an analog source when transmitting the Hybrid waveform. The output of this module is the MF AM HD Radio waveform.

Refer to Figure 14-1 and Figure 14-2 for functional block diagrams of the Hybrid and All Digital transmission subsystems, respectively.

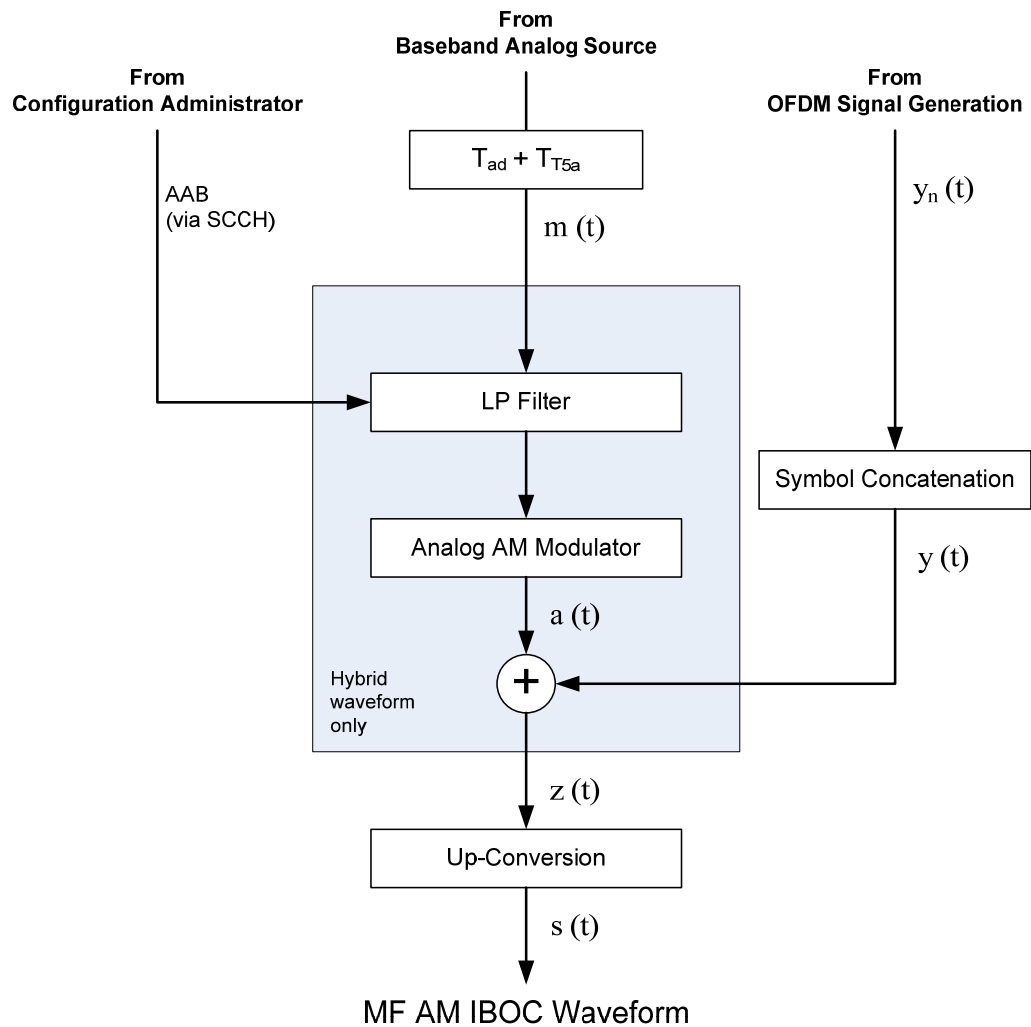

Figure 14-1: Hybrid Transmission Subsystem Functional Block Diagram

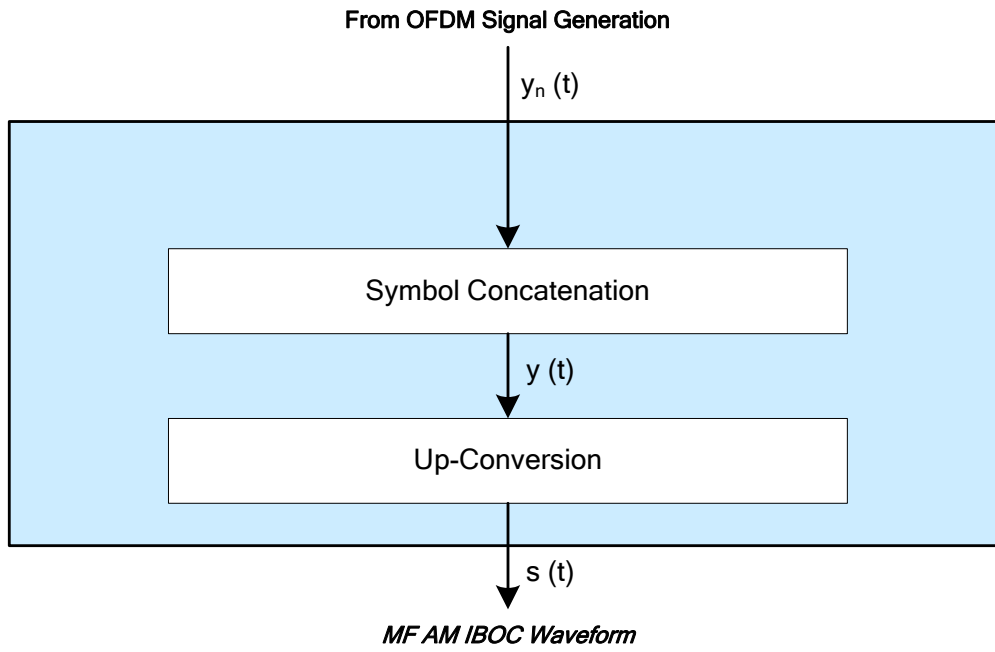

Figure 14-2: All Digital Transmission Subsystem Functional Block Diagram

## 14.2 Functional Components

The functional components of the transmission subsystem are specified in Subsections 14.2.1 through 14.2.6.

### 14.2.1 Symbol Concatenation

The individual time-domain OFDM symbols are summed to produce a continuum of pulses over  $0 \leq t \leq \infty$  as follows:

$$y(t) = \sum_{n=0}^{\infty} y'_n(t)$$

### 14.2.2 Low-Pass Filtering

Low-pass filtering of the analog audio source,  $m(t)$ , is necessary when broadcasting the Hybrid waveform in order to limit interference to the digital subcarriers from the analog host. For the standard digital bandwidth configuration (RDB = 0), the bandwidth of this filter depends on the state of the AAB bit received from the Configuration Administrator. If the AAB bit is zero, the analog audio shall be filtered to a 5 kHz bandwidth according to the 5 kHz specifications in [13]. If the AAB bit is one, the analog audio shall be filtered to an 8 kHz bandwidth according to the 8 kHz specifications in [13].

For the reduced digital bandwidth configuration (RDB = 1), the analog audio shall be filtered to a 9.4 kHz bandwidth according to the 9.4 kHz specifications in [13].

This low-pass filtering can be done in external audio processors also.

### 14.2.3 Analog Diversity Delay

When broadcasting the Hybrid waveform, the digital signal is combined with the analog AM signal, as shown in Figure 14-1. However, analog diversity delay is first applied to the baseband analog AM signal.

In the HD Radio system, the analog and digital signals carry the same audio program with the analog audio delayed from the corresponding digital audio at the output of the analog/digital combiner. This delay consists of a fixed portion  $T_{ad}$ , as defined in Subsection 3.5 (AM System Parameters), plus an adjustable portion  $T_{T5a}$ . The delay is adjusted so that the audio content in the analog and digital paths has a time diversity of precisely  $T_{ad}$  at the TX antenna. This delay accounts for processing delay differences in the two signal paths.

The absolute accuracy of the analog diversity delay, when enabled, is defined in [9].

Ball-game mode: A radio station can disable the analog diversity delay for specialized broadcasts. The state of the analog diversity delay is indicated by the Blend Control bits in the Audio Transport layer (See Reference [4]). However, changing the state of the analog diversity delay may result in a discontinuity during reception as the receiver blends from analog to digital. Some receivers may disable digital reception entirely when analog diversity delay is disabled.

### 14.2.4 Analog AM Modulator

When broadcasting the Hybrid waveform, this process computes the envelope of the analog AM signal by applying a modulation index and adding a DC offset as follows:



$$a(t) = [1 + g \cdot m(t)]$$

where  $a(t)$  is the envelope,  $m(t)$  is the analog source, and  $g$  is the modulation gain. Typically,  $g = 1.25$ , representing a +125% modulation level. The input analog audio source,  $m(t)$ , must be preprocessed external to the AM HD Radio Exciter so that  $a(t)$  does not assume negative values. See Reference [9] for a complete description of the requirements on the input analog audio source.

In addition, the analog signal will be compatible with the Emergency Alert System (EAS) as specified in Title 47 CFR Part 11 (See Reference [11]). The analog spectral emissions mask, per Title 47 CFR §73.317 [12], is contained in Reference [9].

#### 14.2.5 Analog/Digital Combiner

When broadcasting the Hybrid waveform, the real analog AM baseband waveform,  $a(t)$ , is coherently combined with the digital baseband waveform,  $y(t)$ , to produce the complex baseband AM HD Radio Hybrid waveform  $z(t)$ , as follows:

$$\text{Re} [z(t)] = \text{Re} [y(t)] + a(t)$$

$$\text{Im} [z(t)] = \text{Im} [y(t)]$$

The levels of the digital sidebands in the output spectrum are appropriately scaled by OFDM subcarrier mapping (see Section 12). These scale factors are provided in [9].

Changing service modes from any Hybrid service mode to any other Hybrid service mode (including future backward compatible Hybrid service modes) shall not cause any interruptions or discontinuities in the analog signal. Refer to [9] for further details.

#### 14.2.6 Up-Conversion

The concatenated digital signal  $z(t)$  is translated from baseband to the RF carrier frequency as follows:

$$s(t) = \text{Re}\left(e^{j2\pi f_c t} \cdot z(t)\right)$$

where  $f_c$  is the RF channel frequency and  $\text{Re}(\ )$  denotes the real component of the complex quantity. For the All Digital waveform,  $z(t)$  is replaced with  $y(t)$ .

The AM HD Radio waveform is broadcast in the current AM radio band and its power levels and spectral content [9] are limited to be within the spectral mask as defined in 47 C.F.R §73.44.

The carrier frequency spacing and channel numbering schemes are compatible with 47 CFR §73.14. Channels are centered at 10 kHz intervals ranging from 540 to 1700 kHz. Both the analog and digital portions of the Hybrid waveform are centered on the same carrier frequency. The absolute accuracy of the carrier frequency is defined in [9].

## 15 GLOSSARY

For the purpose of better understanding this document, the following definitions apply:

**Absolute L1 Frame Number (ALFN)** - A number assigned to each transmitted L1 frame that provides a reference to absolute time. The start of ALFN 0 occurred at 00:00:00 Coordinated Universal Time (UTC) on January 6, 1980. The start of every subsequent L1 frame occurs at an exact integer multiple of  $T_f$  after that instant in time.

**All Digital waveform** - The transmitted waveform composed of digitally modulated primary, secondary, and tertiary OFDM subcarriers. Use of this waveform may be preceded by an interim phase using the Hybrid waveform. The All Digital waveform is the more robust transmission medium. (See Hybrid waveform.)

**allocated channel** - One of the 117 possible frequency assignments in the AM band, as defined in Reference [12].

**amplitude modulation (AM)** - Modulation in which the amplitude of a carrier wave is varied in accordance with the level of the modulating signal.

**amplitude scale factor** - A factor which multiplies the baseband components of a particular OFDM subcarrier of the transmitted spectrum to constrain the radiated power to a prescribed level.

**analog audio bandwidth control (AAB)** - A parameter that indicates which of two audio bandwidths are to be transmitted in the Hybrid mode. AAB is not applicable in the reduced digital bandwidth configuration (RDB = 1).

**analog signal** - Refers to signals that are modulated on the main carrier by conventional continuously varying amplitude modulation. (See digital signal.)

**BC range** - The range of L1 Blocks,  $m1:m2$ , spanned by a transfer frame, indicating its position within an L1 frame.

**bit mapping** - The last step in the interleaving process. Assigns each subframe bit to a row and column in an interleaver matrix as well as to a unique bit position in the digital word within the interleaver matrix element. This reordering of bits before transmission mitigates the impact of burst errors caused by signal fades and interference.

**BPSK (Binary Phase Shift Keying)** - A form of digital phase modulation that assigns one of two discrete phases, differing by 180 degrees, to the carrier. Each BPSK symbol conveys one bit of information.

**channel encoding** - The process used to add redundancy to each of the logical channels to improve the reliability of the transmitted information.

**characterization parameters** - The unique set of defining parameters (transfer, latency, and robustness) for each logical channel for a given service mode. The channel encoding, interleaving, spectral mapping, and diversity delay of the logical channel determine its characterization parameters.

**code rate** - Defines the increase in overhead on a coded channel resulting from channel encoding. It is the ratio of information bits to the total number of bits after coding.

**convolutional encoding** - A form of forward error correction channel encoding that inserts coding bits into a continuous stream of information bits to form a predictable structure. Unlike a block encoder, a convolutional encoder has memory; its output is a function of current and previous inputs.

**configuration administrator** - The configuration administrator is a system function that configures each of the layers using SCCH information or parameters which do not change often.

**digital signal** - Refers to signals that are digitally modulated on subcarriers by OFDM. (See analog signal.)

**diversity delay** - Imposition of a relative time delay between two channels carrying the same information to defeat non-stationary channel impairments such as fading and impulsive noise.

**fading** - The variation (with time) of the amplitude or relative phase (or both) of one or more frequency components of a received signal.

**frequency modulation (FM)** - Modulation in which the instantaneous frequency of a sine wave carrier is caused to depart from the channel center frequency by an amount proportional to the instantaneous amplitude of the modulating signal.

**grounded conductive structures** - Metal structures connected to earth ground such as towers and bridges that can attenuate and/or re-radiate the MF radio signal.

**Hybrid waveform** - The transmitted waveform composed of the analog AM signal, plus digitally modulated primary and optionally secondary and tertiary OFDM subcarriers. This waveform supports operation of both analog and digital receivers and may be used in an interim phase preceding conversion to the All Digital waveform. (See All Digital waveform.)

**interleaver block** - A logical subdivision of an interleaver partition. Each interleaver block contains 32 rows and C columns (where  $C = 25$  or  $C = 2$ ).

**interleaver depth** - The number of rows in an interleaver matrix. The system employs two interleaver depths: L1 block (32 rows) and L1 frame (256 rows).

**interleaver matrix** - A two-dimensional array used to reorder subframe bits. The AM system uses five different interleaver matrices.

**interleaving** - A reordering of the message bits to distribute them in time (over different OFDM symbols) and frequency (over different OFDM subcarriers) to mitigate the effects of signal fading and interference.

**L1 block** - A unit of time of duration  $T_b$ . Each L1 frame is comprised of 8 L1 blocks.

**L1 block count** - An index that indicates one of 8 equal subdivisions of an L1 frame.

**L1 block rate** - The rate, equal to the reciprocal of the L1 block duration,  $\left(\frac{1}{T_b}\right)$ , at which selected transfer frames are conducted through Layer 1.

**L1 frame** - A specific time slot of duration  $T_f$  identified by an ALFN. The transmitted signal may be considered to consist of a series of L1 frames.

**L1 frame rate** - The rate, equal to the reciprocal of the L1 frame duration,  $\left(\frac{1}{T_f}\right)$ , at which selected transfer frames are conducted through Layer 1.

**latency** - The time delay that a logical channel imposes on a transfer frame as it traverses Layer 1. One of the three characterization parameters. (See robustness and transfer.)

**Layer 1 (L1)** - The lowest protocol layer in the HD Radio protocol stack (also known as the waveform/transmission layer). Primarily concerned with the transmission of data over a communication channel. Includes framing, channel coding, interleaving, modulation, etc. over the AM radio link at the specified service mode.

**Layer 2 (L2)** - The Channel Multiplex layer in the HD Radio protocol stack. Multiplexes data from the several higher layer services into logical channels (partitioned into L1 frames and L1 blocks) for processing in Layer 1.

**L2 protocol data units (PDU)** - Units of user content and upper layer protocol control information transferred from Layer 2 to Layer 1. (See PDU.)

**logical channel** - A signal path that conducts transfer frames from Layer 2 through Layer 1 with a specified grade of service.

**lower sideband** - The group of OFDM subcarriers (subcarriers number -1 through -81) below the carrier frequency.

**mother code** - The complete code sequence generated by a convolutional encoder. (See puncturing.)

**OFDM signal generation** - The function that generates the modulated baseband signal in the time domain.

**OFDM subcarrier** - A discrete frequency-domain signal within the allocated channel that encodes digital data through its amplitude and/or phase. The total set of subcarriers, taken in aggregate for a period of  $T_s$ , provides the digital data for that time interval. (See OFDM symbol.)

**OFDM subcarrier mapping** - The function that assigns the interleaved logical channels to the OFDM subcarriers.

**OFDM symbol** - Time-domain pulse of duration  $T_s$ , representing all the active subcarriers and containing all the data in one row of all the interleaver matrices and a bit from the system control data sequence vector. The transmitted waveform is the concatenation of successive OFDM symbols.

**Orthogonal Frequency Division Multiplexing (OFDM)** - A parallel multiplexing scheme that modulates a data stream onto a large number of orthogonal subcarriers that are transmitted simultaneously. (See OFDM symbol.)

**parity** - In binary-coded data, a condition maintained so that in any permissible coded expression, the total number of “1”s or “0”s is always odd, or always even.

**power level control (PL)** - In the Hybrid waveform, the nominal level of the secondary, PIDS, and tertiary sidebands (relative to the analog carrier) is one of two selectable values: low or high. Power level control (PL) specifies which level is to be employed, where PL=0 selects the low level and PL=1 selects the high level.

**primary sidebands** - The OFDM sidebands consisting of subcarriers 57 through 81 and -57 through -81 with the Hybrid waveform and subcarriers 2 through 26 and -2 through -26 with the All Digital waveform.

**pulse-shaping function** - A time-domain pulse superimposed on the OFDM symbol to improve its spectral characteristics.

**puncturing** - The process of removing selected bits from the mother codeword to increase FEC code rate.

**Protocol Data Unit (PDU)** - A Protocol Data Unit (PDU) is the structured data block in the HD Radio system that is produced by a specific layer (or process within a layer) of the transmitter protocol stack. The PDUs of a given layer may encapsulate PDUs from the next higher layer of the stack and/or include content data and protocol-control information originating in the layer (or process) itself. The PDUs generated by each layer (or process) in the transmitter protocol stack are inputs to a corresponding layer (or process) in the receiver protocol stack.

**QPSK (Quadrature Phase Shift Keying)** - A form of digital phase modulation that assigns one of four discrete phases, differing by 90 degrees, to the carrier. Each QPSK symbol conveys two bits of information.

**reduced digital bandwidth control (RDB)** - A parameter that is used to limit the spectrum of the MA1 and MA3 waveforms. In service mode MA1, RDB may be used to reduce interference to the analog host and accommodate an analog bandwidth of up to 9.4 kHz. In service mode MA3, RDB may be used reduce interference to adjacent channels

**robustness** - The ability of a logical channel to withstand channel impairments such as noise, interference, and fading. There are eight distinct levels of robustness designed into Layer 1 of the AM air interface. One of the three characterization parameters. (See latency and transfer.)

**scrambling** - The process of modulo-2 summing the input data bits with a pseudo-random bit stream to randomize the time-domain bit stream.

**secondary sidebands** - The OFDM sidebands consisting of subcarriers 27 through 53 and -27 through -53 in the Hybrid mode and subcarriers 27 through 52 in the all digital mode.

**service mode** - A specific configuration of operating parameters specifying throughput, performance level, and selected logical channels.

**service mode control** - Control information passed over the SCCH from the Configuration Administrator to Layer 1 which determines the service mode for Layer 1.

**signal constellation mapper** - The process in OFDM subcarrier mapping that associates sets of bits with specific 64-QAM, 16-QAM, QPSK, or BPSK states.

**spectral emissions mask** - A specification setting the maximum level of out-of-band components of the transmitted signal.

**spectral mapping** - The association of specific logical channels with specific subcarriers or groups of subcarriers.

**subframe generation** - The first step in the interleaving process. Splits the bits of each active input transfer frame into multiple subframes and, at the same time, reorders the bits. The number of subframes for an active logical channel, the division and order of transfer frame bits, and the number of transfer frames needed to fill the subframes, are all dependent upon service mode.

**system control** - Data from the Configuration Administrator conveying control such as service mode, power level, analog audio bandwidth, and analog diversity delay.

**system control channel (SCCH)** - A channel which transports control information from the Configuration Administrator to Layer 1 and also conveys status information from Layer 1 to Layer 2, through the system control processing.

**system control data sequence** - A sequence of bits destined for each reference subcarrier representing the various system control components relayed between Layer 1 and Layer 2.

**system control processing** - The function that generates the system control data sequence.

**symbol concatenation** - The process of concatenating individual OFDM symbol pulses in time to produce a continuous time-domain signal.

**system protocol stack** - The protocols associated with operation of the various functional layers.

**system time alignment,  $T_{st}$**  - Internal time delay to absorb variations in internal processing time to maintain message alignment with L1 frames and blocks.

**tertiary sidebands** - The OFDM sidebands consisting of subcarriers 2 through 26 and -2 through -26 with the Hybrid Waveform and subcarriers -27 through -52 with the All Digital waveform.

**training** - A known pattern or sequence of bits, the training pattern or training sequence, is intermingled in the transmitted data sequence to allow the receiver to detect and correct for the effects of non-uniform channel effects over the transmission path and receiver front end.

**transfer** - A measure of the data throughput through a logical channel. One of the three characterization parameters. (See latency and robustness.)

**transfer frame** - An ordered, one-dimensional collection of data bits of specified length grouped for processing through a logical channel for exchange with the physical layer.

**transfer frame number** - A number,  $F_{m1:m2}^n$ , that specifies the ALFN,  $n$ , and BC range,  $m1:m2$ , associated with a particular transfer frame, in order to relate the transfer frame to absolute time.

**transfer frame rate** - The number of transfer frames per second.

**transfer frame size** - The number of bits in a transfer frame.

**transmission subsystem** - The functional component used to format and up-convert the baseband HD Radio waveform for transmission through the medium frequency (MF) channel.

**transmit time alignment,  $T_{T1a}$**  - Adjusted so that the digital time diversity between main and backup is precisely  $T_{dd}$  at the transmit antenna.

**transmit audio alignment,  $T_{T5a}$**  - Adjusted so that the audio content in the analog and digital paths has a time diversity of precisely  $T_{ad}$  at the TX antenna (applies to hybrid service modes only)

**upper sideband** - The group of OFDM subcarriers (subcarriers number +1 through +81) above the carrier frequency.

**vector** - A one-dimensional array.